



[CLICK for More Info Online](#)

## Adjustable-Length Billet-Aluminum Throttle Linkage



Our billet-aluminum throttle linkage directly replaces the bent design factory rod found on early Ford/Mercury vehicles. Stainless steel adapter components match the inner diameter of the factory pedal rod facilitating a direct, trouble-free installation. The straight length of 6061-T6 hex rod eliminates the possibility of deflection along the linkage and resulting reduction of throttle response. The rod uses left- and right-hand threads at opposite ends to enable a simple adjustment feature not possible with the factory linkage. Jam nuts secure the adjusted length and ensure the rod ends remain correctly indexed. Two-piece, mild-steel rod ends with high-carbon chromium steel spherical bearings reduce friction at the pivot points and improve pedal feel and consistency. All components are anodized, zinc plated, or stainless steel for corrosion protection and long lasting performance.

### Features

- Eliminates deflection in throttle rod
- Direct, positive throttle response
- Adjustable length for perfect fit installations
- Spherical bearing pivot points
- Available in two different lengths

## Exploded View

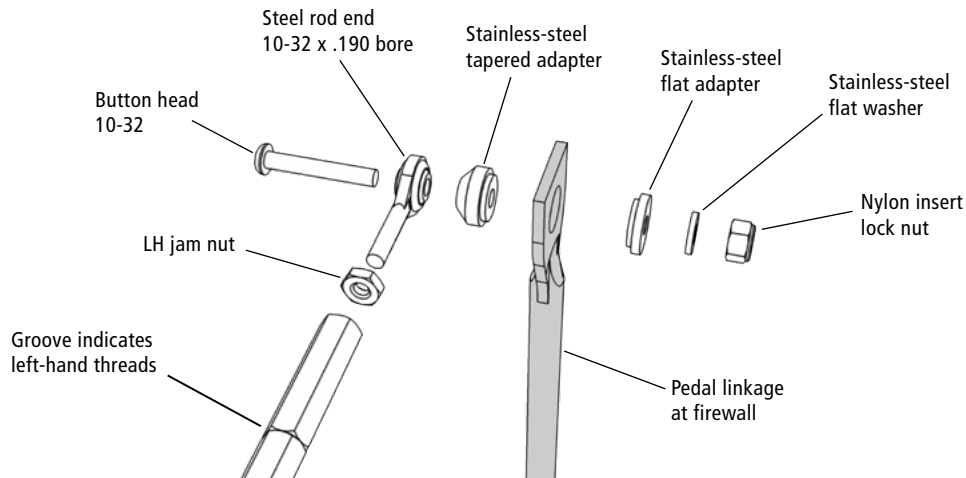

## Dimensions

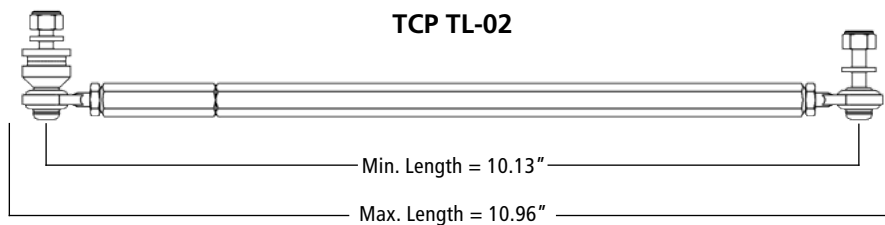
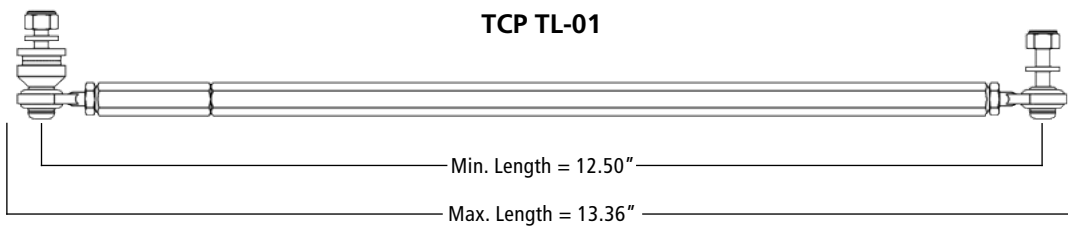

## Applications

Model	Year	390, 427, 428	260, 289, 302
Cougar	1967-1968	TCP TL-01	TCP TL-02
Mustang	1965-1968	TCP TL-01	TCP TL-02

All prices subject to change. Current pricing available at [www.cachassisworks.com](http://www.cachassisworks.com).



Total Control Products  
8661 Younger Creek Drive - Sacramento, CA 95828  
A Chris Alston's Chassisworks, Inc. Brand

Order: 800-722-2269  
Tech: 916-388-0288  
Fax: 916-388-0295

[tcpsales@cachassisworks.com](mailto:tcpsales@cachassisworks.com)  
[tcptech@cachassisworks.com](mailto:tcptech@cachassisworks.com)  
[www.totalcontrolproducts.com](http://www.totalcontrolproducts.com)