

INSTALLATION GUIDE



Upper Coil-Over Mount Support Ring Set

For use with early version TCP front coil-over kit

P/N: TCP COLVF-06

DESCRIPTION:

SUPPORT RING AND REQUIRED HARDWARE FOR UPPER SHOCK MOUNT

APPLICATIONS:

FITS 60-73 MUSTANG/COUGAR WITH EARLY TCP FRONT COIL-OVER

IMPORTANT: The outer shock tower reinforcement plate and suspension bump stop must be reinstalled prior to operating the vehicle. Worn or damaged suspension bump stops must be replaced. Failure to provide a proper compression-travel suspension stop will cause unwarrantable damage to the shock absorber and possible structural damage to the chassis.

WARRANTY NOTICE:

There are **NO WARRANTIES**, either expressed or implied. Neither the seller nor manufacturer will be liable for any loss, damage or injury, direct or indirect, arising from the use or inability to determine the appropriate use of any product. Before any attempt at installation, all drawings and/or instruction sheets should be completely reviewed to determine the suitability of the product for its intended use. In this connection, the user assumes all responsibility and risk. We reserve the right to change specification without notice. Further, Chris Alston's Chassisworks, Inc., makes **NO GUARANTEE** in reference to any specific class legality of any component. **ALL PRODUCTS ARE INTENDED FOR RACING AND OFF-ROAD USE AND MAY NOT BE LEGALLY USED ON THE HIGHWAY.** The products offered for sale are true race-car components and, in all cases, require some fabrication skill. **NO PRODUCT OR SERVICE IS DESIGNED OR INTENDED TO PREVENT INJURY OR DEATH.**



Total Control Products

A Chris Alston's Chassisworks, Inc. Brand

8661 Younger Creek Drive

Sacramento, CA 95828

Phone: 916-388-0288

Technical Support: tcptech@cachassisworks.com

PARTS LIST

Item	Part Number	Description	Qty.
1	7909-032	Upper Shock Mount Support Ring	2
-	7918-035	Hardware Bag for TCP COLVF-06	1

7918-035 Hardware Bag for TCP COLVF-06

A	3101-038-16C	Locknut 3/8-16 Nylon Insert	6
B	3104-038C1.75C	Button Head 3/8-16 x 1-3/4"	6
C	3120-038S-Y	Washer Hardened 3/8 Flat SAE	12
D	7909-051	Spot Weld Removal Bit, 3/8"	1
Z	-	Upper Coil-Over Shock Mount – <i>Supplied with original coil-over kit.</i>	0

INSTRUCTIONS

- Jack-up vehicle so that suspension is fully extended.
 - Secure with jack stands.
- Unbolt coil-over shock from upper and lower mounts.
 - Remove shock.
- For 67-73 only:** upper spring seat must be removed.
 - Drill out 3 spot welds from factory spring-seat (Figure 2-1), using supplied tool (Item D).
 - Once you have drilled through spring seat material, use a pry bar to break remaining bit of material.
 - Any remaining material must be ground flush and painted.
- Secure upper shock mount (Item Z) to shock tower using hardware shown in illustration (Figure 2-2).
 - Torque to 30 lb. ft.
- Install coil-over shock assembly reusing original hardware.
 - Torque to 60 lb. ft.
- Check all mounting hardware.



Figure 2-1

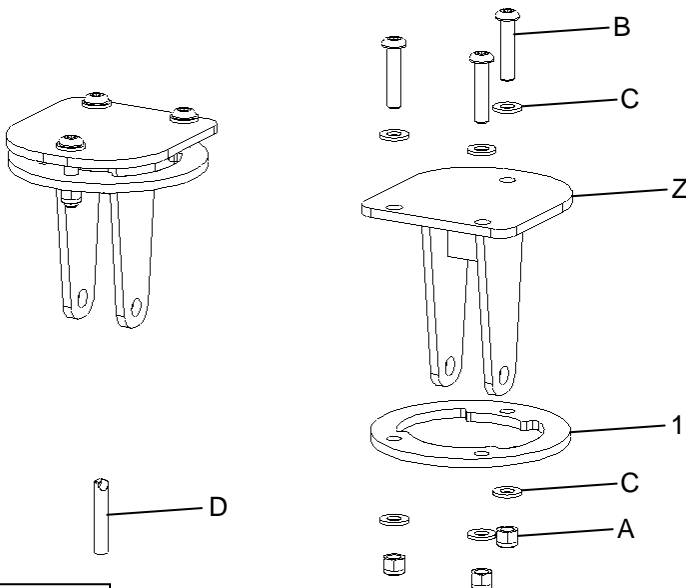

Figure 1-1

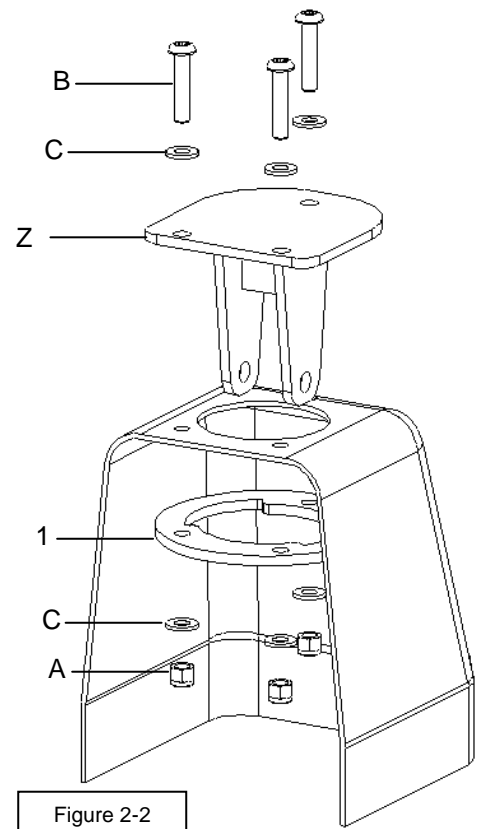

Figure 2-2