

-WARRANTY NOTICE:

There are **NO WARRANTIES**, either expressed or implied. Neither the seller nor manufacturer will be liable for any loss, damage or injury, direct or indirect, arising from the use or inability to determine the appropriate use of any product. Before any attempt at installation, all drawings and/or instruction sheets should be completely reviewed to determine the suitability of the product for its intended use. In this connection, the user assumes all responsibility and risk. We reserve the right to change specification without notice. Further, Chris Alston's Chassisworks, Inc., makes **NO GUARANTEE** in reference to any specific class legality of any component. **ALL PRODUCTS ARE INTENDED FOR RACING AND OFF-ROAD USE AND MAY NOT BE LEGALLY USED ON THE HIGHWAY.** The products offered for sale are true race-car components and, in all cases, require some fabrication skill. **NO PRODUCT OR SERVICE IS DESIGNED OR INTENDED TO PREVENT INJURY OR DEATH.**

INSTALLATION GUIDE



Tie Rod Adapter Set

.460 minor diameter

P/N: TCP TIER-01



Total Control Products

A Chris Alston's Chassisworks, Inc. Brand

8661 Younger Creek Drive

Sacramento, CA 95828

Phone: 916-388-0288

Technical Support: tcptech@cachassisworks.com

7903-TIER-01

REV 04/01/10

DESCRIPTION:

TIE ROD ADAPTER SET WITH .46 MINOR DIAMETER.
ADAPTS OEM INNER TIE ROD TO RACK-&PINION CENTER LINK

APPLICATIONS:

FITS '60-65 FALCON/COMET AND '64-66 MUSTANGS USING
TCP RACK-&PINION AND OEM INNER TIE RODS

PARTS LIST

Item	Part Number	Description	Qty
1	3120-044S-Y	Washer 7/16 Flat SAE	4
2	3131-044-20Y	Locknut, 7/16-20 Nylon Insert	2
3	7900-200	Tapered Adapter .46 Minor Diameter	2
4	Not Supplied	Inner Tie Rod, 65-66 V8 Mustang	2
5	Not Supplied	Castle Nut, 7/16-20, 11/16 Hex	2
6	Not Supplied	Cotter Pin, 3/32 x 1	2

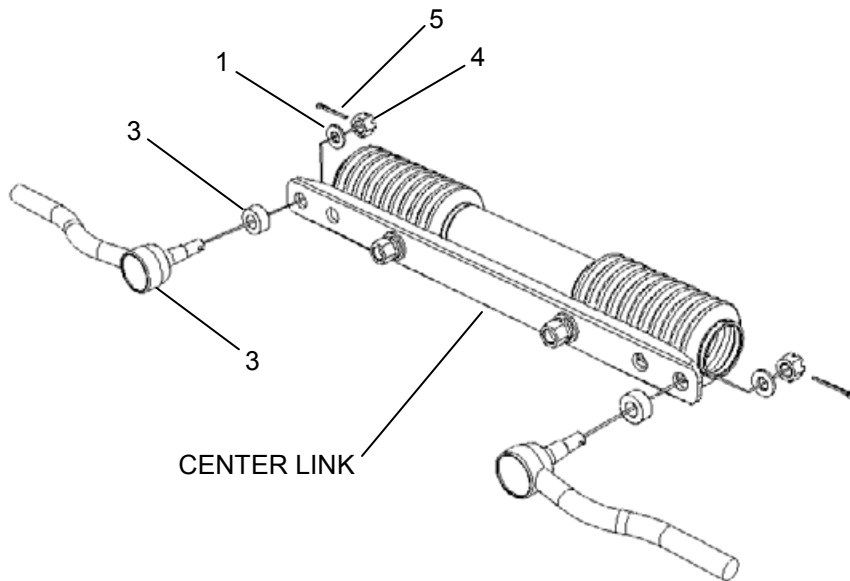

INFORMATION

- Tapered adapter must be mounted in outermost holes of Center Link.
- It is NOT necessary to use the power steering version of driver-side inner tie rod with our power rack-&-pinion.
- Different tie-rod manufacturers may use longer studs that make contact with rubber boots during operation. These studs will have to be ground to a shorter length preventing contact and damage to protective boots.
- Locknuts can be used instead of castle nuts if stud requires shortening.
- To compensate for reproduction-tie-rod taper differences, additional flat washers have been included. Place washers underneath the castle nut or locknut to remove free play if needed.
- Torque nuts to 35-45 lb. ft.
- Bend prongs of cotter pins in opposite directions until they are somewhat flat against nut to prevent pin from rotating and damaging protective boots.