

# INSTALLATION GUIDE



## Upper Control Arms 04 For 1966-1977 Fords with Coil-Over Suspension

**P/N: TCP UCA-04**

### DESCRIPTION:

UPPER TUBULAR CONTROL ARM, 4.75" HOLE SPACING, WITHOUT SPRING PERCH TABS

### APPLICATIONS:

FITS COMET 66-67 & 71-77, COUGAR 67-73, CYCLONE 66-71, FAIRLANE 66-71, FALCON 66-70, MAVERICK 70-77, MONTEGO 68-71, MUSTANG 67-73, RANCHERO 66-71, TORINO 68-71

NOTE: EXCLUDES 70 BOSS 429

**IMPORTANT:** The outer shock tower reinforcement plate and suspension bump stop must be reinstalled prior to operating the vehicle. Worn or damaged suspension bump stops must be replaced. Failure to provide a proper compression-travel suspension stop will cause unwarrantable damage to the shock absorber and possible structural damage to the chassis.

### WARRANTY NOTICE:

There are **NO WARRANTIES**, either expressed or implied. Neither the seller nor manufacturer will be liable for any loss, damage or injury, direct or indirect, arising from the use or inability to determine the appropriate use of any product. Before any attempt at installation, all drawings and/or instruction sheets should be completely reviewed to determine the suitability of the product for its intended use. In this connection, the user assumes all responsibility and risk. We reserve the right to change specification without notice. Further, Chris Alston's Chassisworks, Inc., makes **NO GUARANTEE** in reference to any specific class legality of any component. **ALL PRODUCTS ARE INTENDED FOR RACING AND OFF-ROAD USE AND MAY NOT BE LEGALLY USED ON THE HIGHWAY.** The products offered for sale are true race-car components and, in all cases, require some fabrication skill. **NO PRODUCT OR SERVICE IS DESIGNED OR INTENDED TO PREVENT INJURY OR DEATH.**

Total Control Products  
A Chris Alston's Chassisworks, Inc. Brand  
8661 Younger Creek Drive  
Sacramento, CA 95828  
Phone: 916-388-0288  
Technical Support: [tcptech@cachassisworks.com](mailto:tcptech@cachassisworks.com)



# PARTS LIST

| Item | Part Number | Description   | Qty |
|------|-------------|---|-----|
| -    | 7905-020    | Upper Assembly 4.75" without Tabs Control Arm                         | 2   |
| -    | 7918-022    | Hardware Bag for TCP UCA-03, TCP UCA-04                               | 1   |
| Z    | 7905-023    | Upper Balljoint, 4-Bolt (Subparts indicated as Items Z-1 through Z-9) | 2   |

*7902-020 Arm Assembly (Subparts list)*

|   |                |  |   |
|---|----------------|--|---|
| 1 | 3100-063F1.75Y | Bolt 5/8-18 x 1-3/4" Hex Head Cap Screw            | 2 |
| 2 | 3108-063L-C    | Lock Washer 5/8 Regular                            | 2 |
| 3 | 3112-075X063-R | Rod End RH 3/4 thread x 5/8 Bore x 3/4 ball width  | 2 |
| 4 | 3120-063S-Y    | Washer Hardened 5/8 Flat SAE                       | 2 |
| 5 | 3102-075-16RC  | Jam Nut 3/4-16 RH 1-1/8 Hex x .42 Tall             | 2 |
| 6 | 3102-075-16LC  | Jam Nut 3/4-16 LH 1-1/8 Hex x .42 Tall             | 2 |
| 7 | 7905-002       | Pivot Shaft 1" x 1", 1/2" Holes 4.75 Apart         | 1 |
| 8 | 7905-003       | Coupler Male-Female 3/4-16 x 3/4-16 x 3-3/4 Length | 2 |
| 9 | 7905-016       | Upper Arm Weldment without Tabs                    | 1 |

*7918-022 Hardware Bag (Subparts list)*

|   |                |  |   |
|---|----------------|--|---|
| A | 3100-050C2.50Y | Bolt 1/2-13 x 2-1/2" Hex Head Cap Screw          | 4 |
| B | 3108-050L-C    | Lock Washer 1/2 Regular                          | 4 |
| C | 3110-050-13C   | Nut 1/2-13 Standard 3/4 Hex x .44 Tall           | 4 |
| D | 3120-050S-Y    | Washer Hardened 1/2 Flat SAE                     | 8 |
| E | 7905-026       | Mounting Shim 1/2" Holes 3.75 Apart x .100 Thick | 2 |
| F | 7905-029       | Grease Zerk 1/4-28 x 45°                         | 1 |

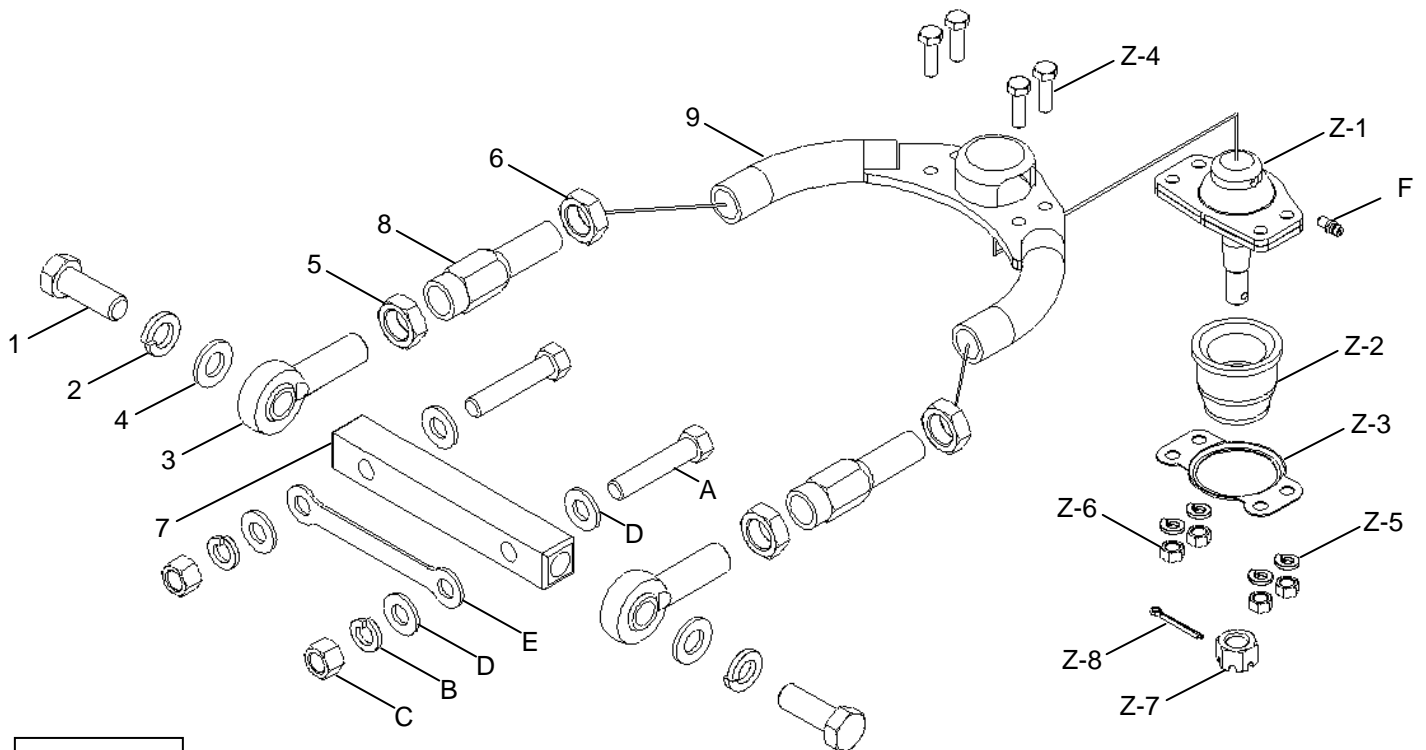

Figure 1-1

# INSTRUCTIONS

1. Raise front end of car and secure with jack stands.
  - a. Wheels must not be in contact with ground.
2. Remove wheels, making note of which side of vehicle they were removed.
3. Unbolt lower shock mount from spring perch (Figure 2-1).
4. Unbolt upper shock mount from shock tower (Figure 2-2).
  - a. If replacing the shock, unbolt shock from upper mount prior to unbolting mount.
5. Remove shock and mount from vehicle (Figure 2-3).

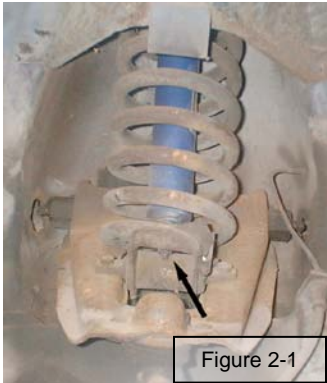

Figure 2-1

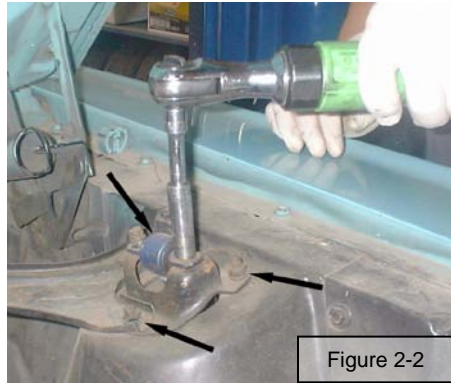

Figure 2-2



Figure 2-3

6. Using a spring compressor, remove the coil spring.
  - a. Follow the tool manufacturer's instructions for proper use of the spring compressor.
7. Unbolt lower spring perch from control arm.
8. Secure lower control arm and spindle assembly.
  - a. Place a jack stand under the lower control arm.
  - b. Keep spindle assembly in upright position to prevent damage to brakelines. Heavy wire or tie down straps can be used.
9. Remove cotter pin from upper balljoint.
10. Remove upper balljoint castle nut.
11. Using a pickle fork, separate upper balljoint from spindle.
  - a. A large hammer can also be used to strike upright near balljoint. The jarring force will unseat the balljoint stud.
12. Remove upper arm pivot shaft nuts from engine side of shock tower, and remove upper arm.
13. New holes must be drilled to mount upper arm.
  - a. If TCP Drill Jig was purchased, proceed with instructions #7903-TOOL-02 included with Drill Jig #TCP TOOL-02.
  - b. If performing modification without TCP Drill Jig, drill holes as illustrated (Figure 2-4).

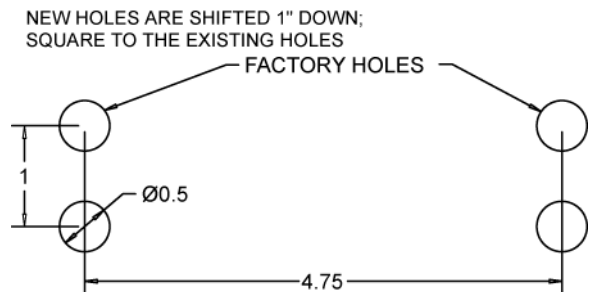

Figure 2-4

Once holes have been drilled proceed with Step 14

14. Bolt upper control arm pivot shaft to shock tower at lowered mounting location (Figure 2-5).
  - a. Mounting shim (Item H) is only needed to compensate for variances in shock tower alignment. It may be necessary to use both on one side or none.
  - b. Torque hardware to 95 lb. ft.

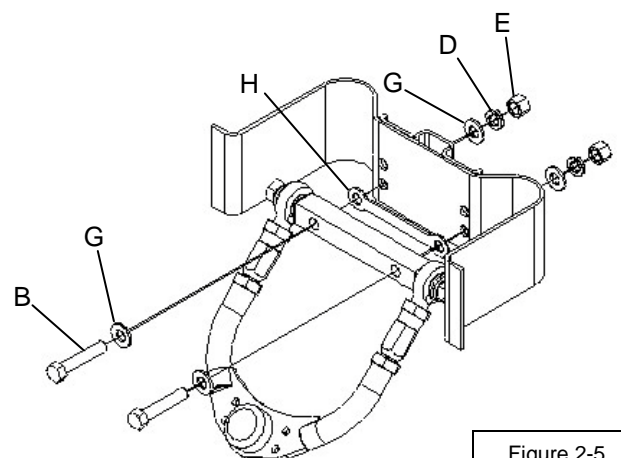

Figure 2-5

15. Place upper balljoint stud into spindle upright tapered seat.
  - a. Install castle nut.
    - i. Torque to 75-80 lb. ft.
  - b. Install cotter pin.
    - i. Bend ends in opposite directions so that they wrap around the stud.
16. Check all mounting hardware.
17. Balljoints can now be lubricated using standard grease gun.

Refer to *Coil-Over instructions #7903-COLVF-XX* to complete front suspension installation.

## ALIGNMENT

*The vehicle must be professionally inspected and aligned prior to regular use.*

Your alignment will need to be somewhat close to final specs in order to safely drive your vehicle to the alignment shop if a trailer is not available.

Visually determine if the front wheels look straight. They should not appear to “toe” (left to right) in or out. The outside of the wheels should also be very close to vertical. A few degrees of negative camber (leaning in) are acceptable. Read below for specific instructions on making adjustments.

**Tighten jam nuts when finished.**

- Loosen jam nuts to allow adjustment of the couplers.
- A thread lubricant is recommended to make adjusting easier and to prevent damage to threads.
- Both Caster and Camber adjustments can be made at upper arm.
- Turning adjustment couplers in same direction equal amounts will adjust camber.
- Turning adjustment couplers in opposite direction equal amounts will adjust caster.

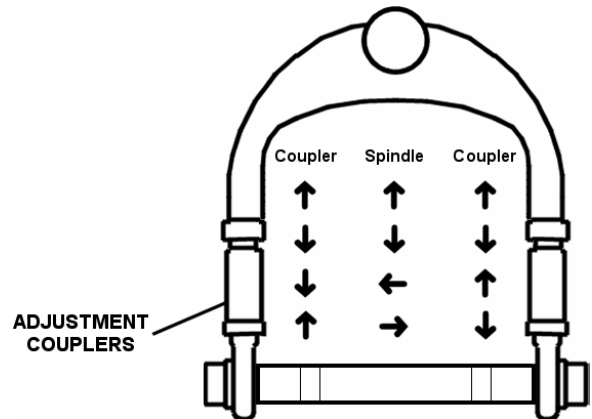

| Application | Camber      | Caster       | Toe              |
|-------------|-------------|--------------|------------------|
| Street      | 0° to -1/2° | 2 1/2° to 3° | 1/16" to 1/8" IN |
| Track       | 1° to 2°    | 2 1/2° to 3° | 1/32" to 1/8" IN |