

READ ALL INSTRUCTIONS COMPLETELY AND THOROUGHLY UNDERSTAND THEM BEFORE DOING ANYTHING.  
CALL CHASSISWORKS TECH SUPPORT (916) 388-0288 IF YOU NEED ASSISTANCE.

# INSTALLATION GUIDE



## 7723-M10

### Rocker-Arm IRS Rear Frame Clip for '64-70 Mustang

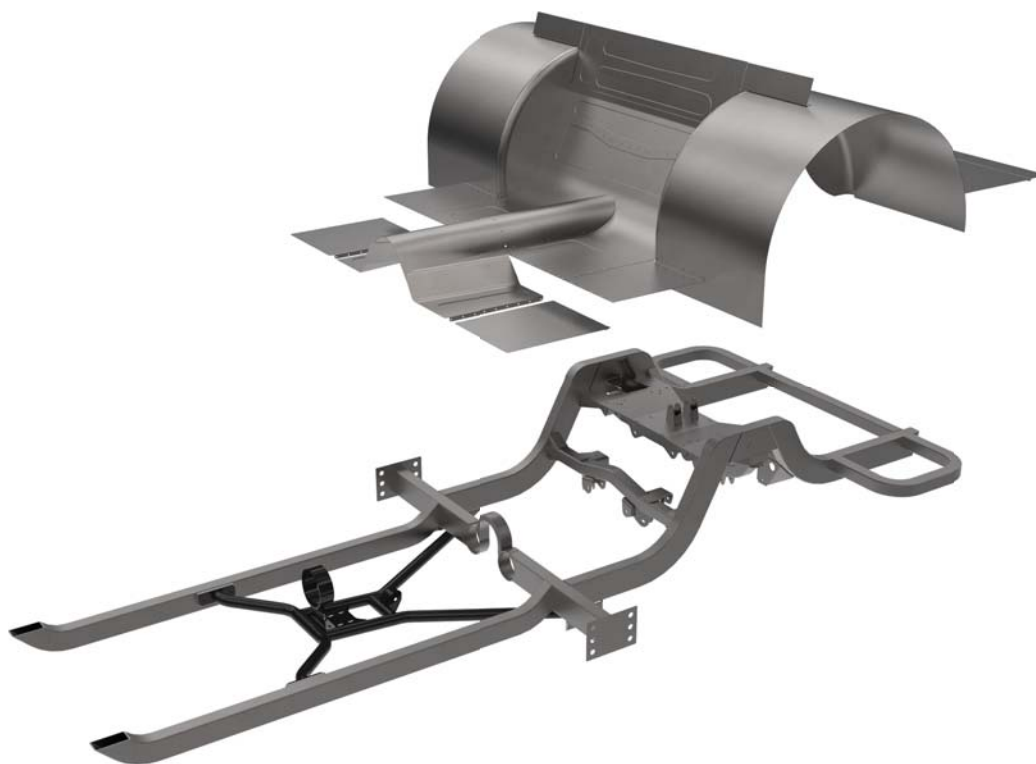

**Description:** Rear frame clip for Rocker-Arm IRS System. Contains factory-welded frame clip, complete rear floor to tail light panel, builder tubs with extensions and rear firewall between tubs. Optional subframe connectors and center support. Suspension sold separately.

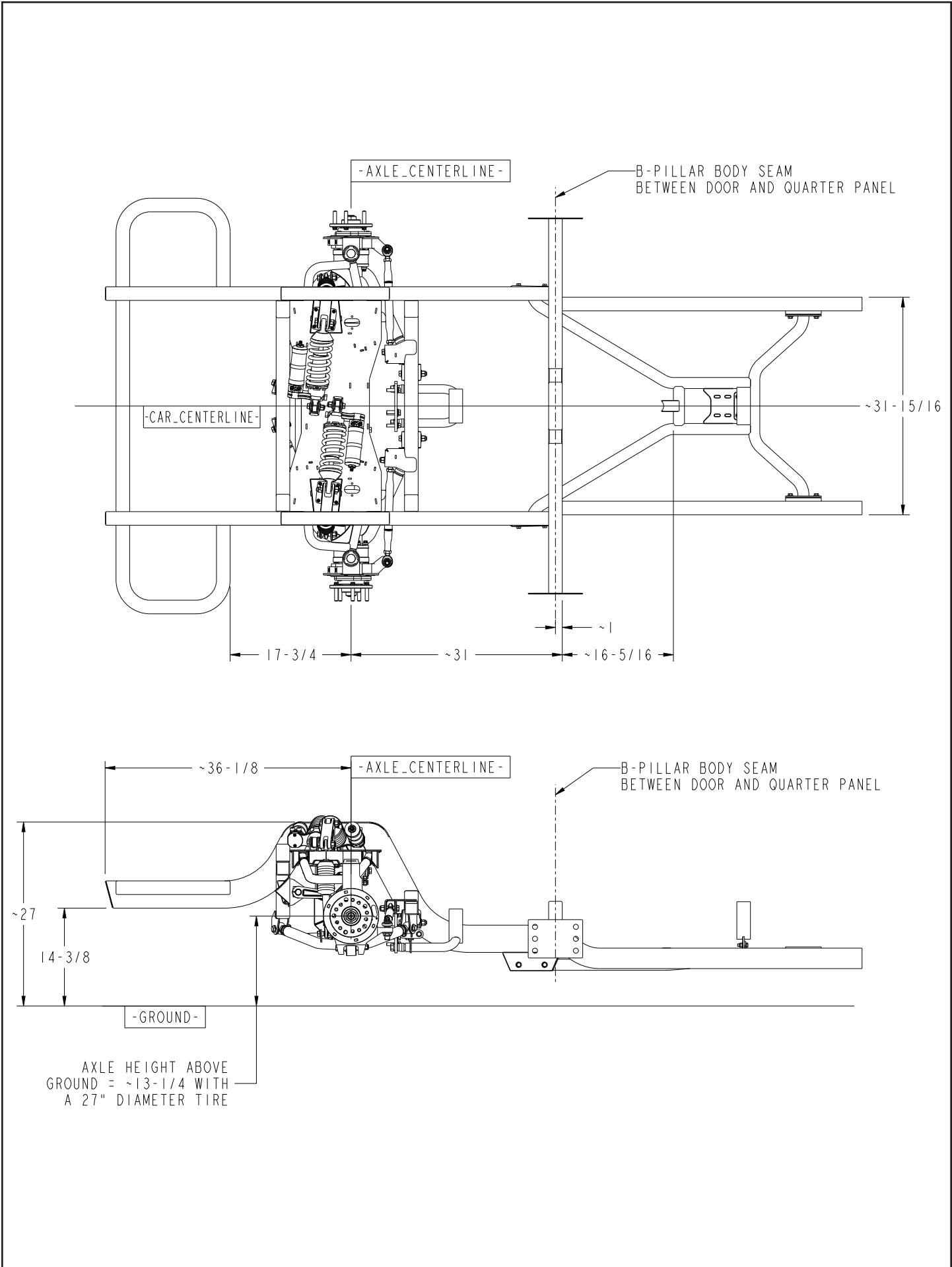

NOTES:

I INSTALLED BY CUSTOMER

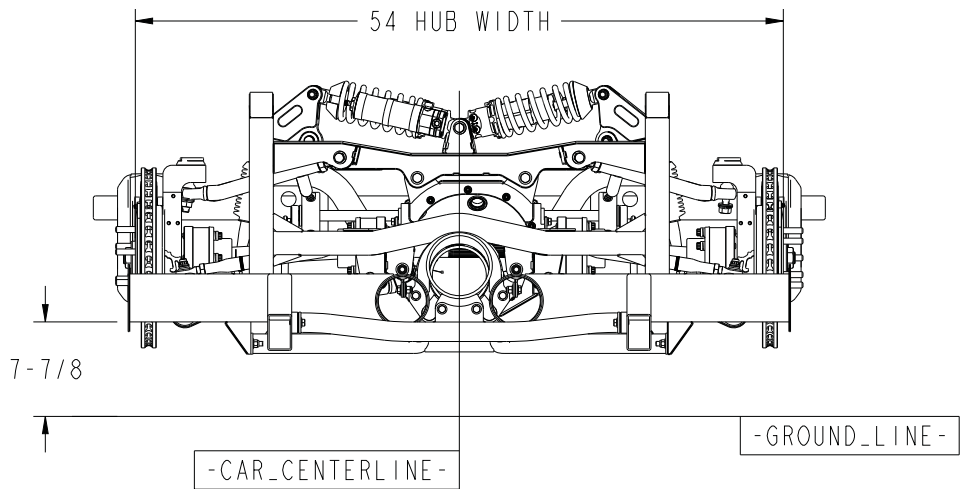
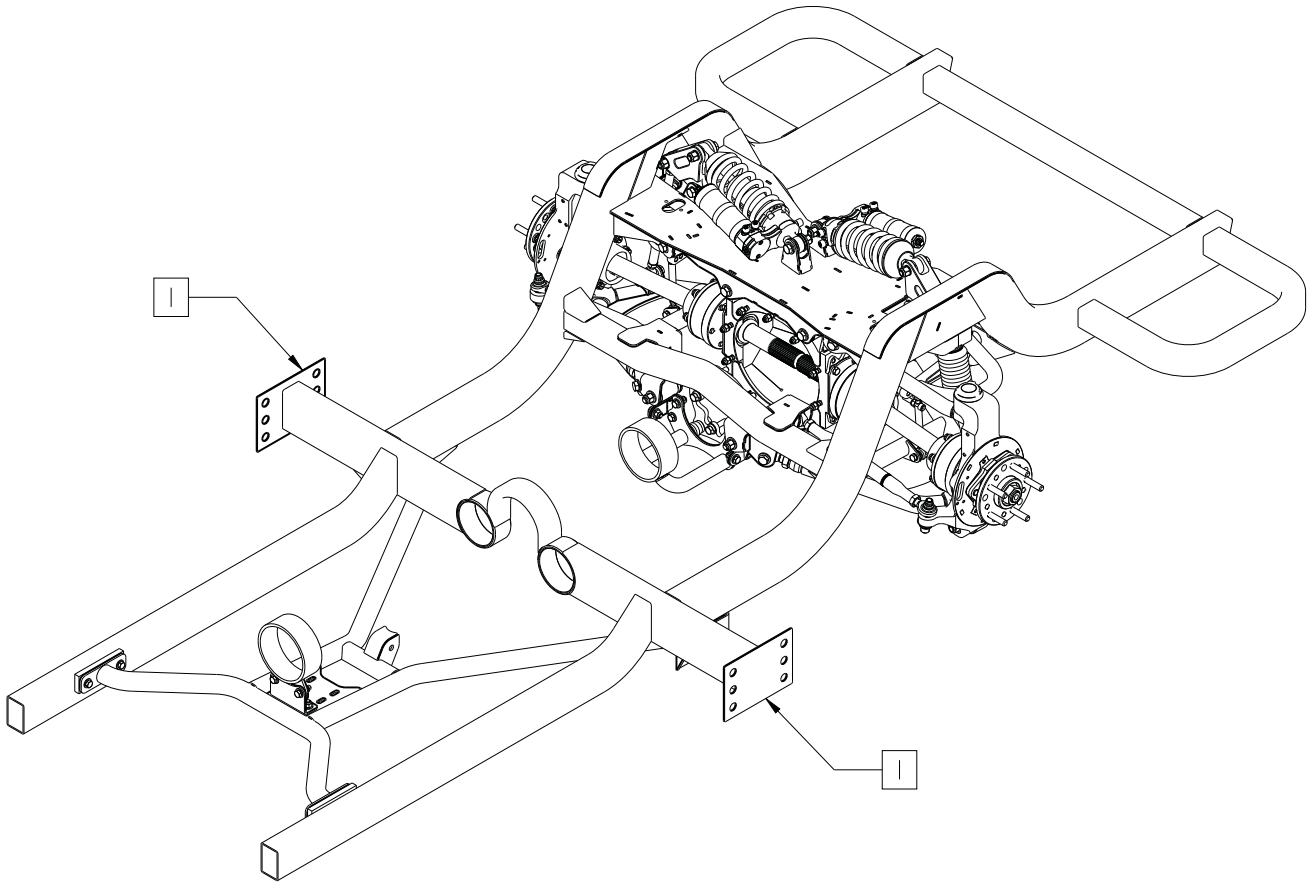

DESCRIPTION	<b>4 x 2 REAR FRAME, IRS, ROCKER, M10, 35 WIDE</b>	
<i>Chris Alston's</i> <b>CHASSISWORKS INC.</b> 8661 YOUNGER CREEK DRIVE SACRAMENTO, CA 95828 (916) 388-0288 FAX 388-0295	PART NO.	<b>7723-M10</b>
	6/1/20	DWG: 7951-7723M10

ITEM	QTY	PART NO.	DESCRIPTION
1	1	7972-2690-35	4 x 2 REAR CLIP, 35" WIDE, ROCKER SHOCK, M10 S/M GROUND CLEARANCE IRS
2	2	7972-2410	SUBFRAME CONNECTOR, G-STREET M10 MUSTANG
3	2	7972-2409	DOUBLER PLATE, ROCKER G-STREET M10 MUSTANG
4	1	7908-068	CENTER SUPPORT WELDMENT HARD TOP, TORQUE ARM STYLE
5	2	7908-074	MOUNTING BLOCK, FRONT, CENTER SUPPORT, S/M GC MUSTANG
6	2	7908-058	SHIM, 1/16 CENTER SUPPORT, TCP
7	20	3120-038S-Y	FLAT WASHER, 3/8 SAE, HARDENED, YELLOW ZINC
8	6	3100-038CI.00Y	HEX BOLT, 3/8-16 x 1, GRADE 8, YELLOW ZINC
9	1	7908-075	REAR MOUNTING BRACKET, DRV, CENTER SUPPORT, S/M GC IRS, M10
10	1	7908-076	REAR MOUNTING BRACKET, PSGR, CENTER SUPPORT, S/M GC IRS, M10
11	6	3100-038CI.25Y	HEX BOLT, 3/8-16 x 1 1/4, GRADE 8, YELLOW ZINC
12	8	3101-038-16C	LOCKNUT 3/8-16, GRADE 5, NYLON INSERT, CLEAR ZINC
13	1	7908-073	ADJUSTER BRACKET, 2 1/8, DRIVESHAFT LOOP, TCP
14	1	7908-070	DRIVESHAFT LOOP WELDMENT, TCP

NOTES:

- 1 POSITION USING CENTER SUPPORT, ITEM #4  
AS A WELDING LOCATION FIXTURE

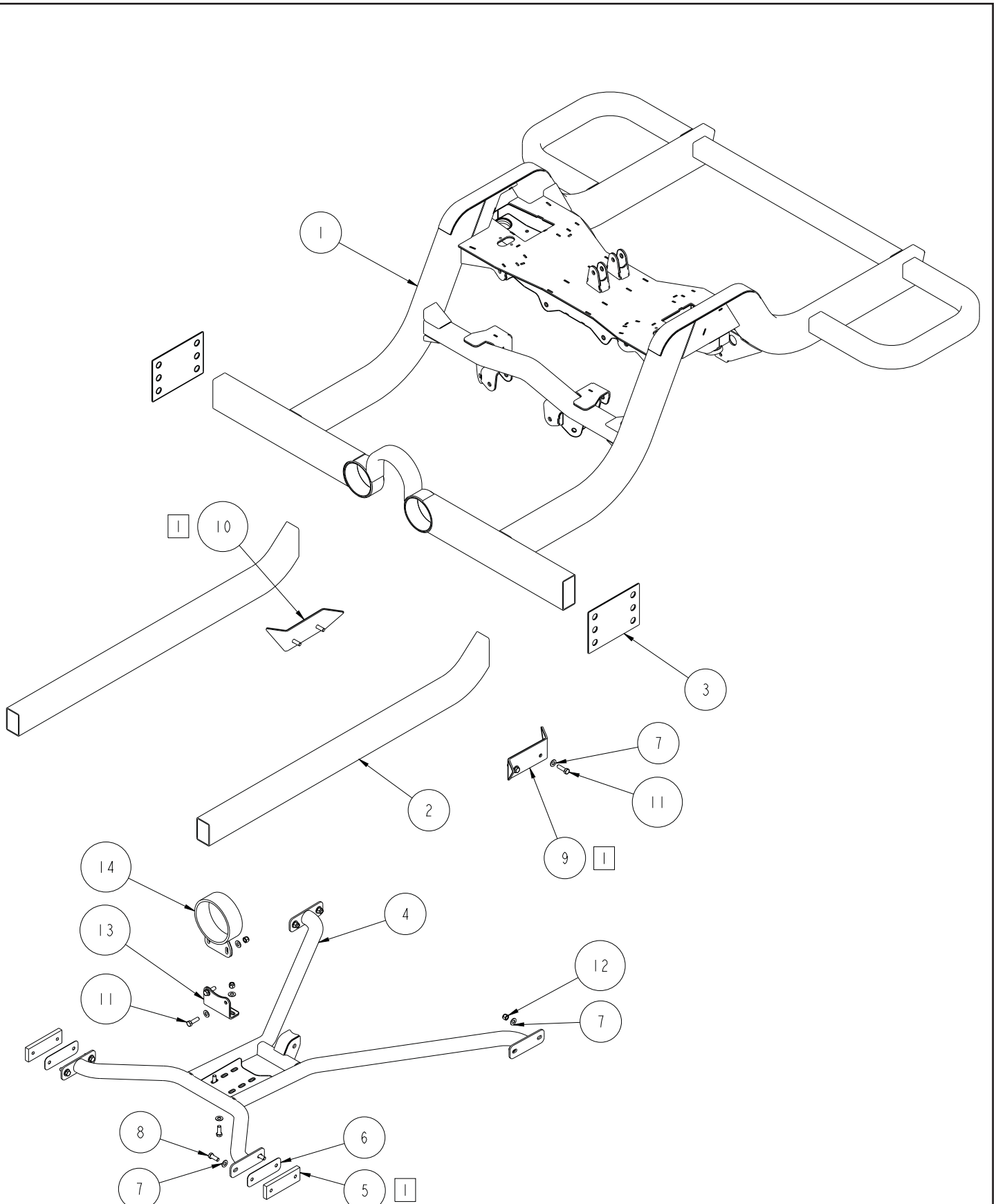

DESCRIPTION	<b>4 x 2 REAR FRAME, IRS, ROCKER, M10, 35 WIDE</b>	
<i>Chris Aston's</i> <b>CHASSISWORKS INC.</b> 8661 YOUNGER CREEK DRIVE SACRAMENTO, CA 95828 (916) 388-0288 FAX 388-0295	PART NO.	<b>7723-M10</b>
	6/1/20	DWG: 7951-7723M10

ITEM	QTY	PART NO.	DESCRIPTION
1	1	7972-2690-35	4 x 2 REAR CLIP, 35" WIDE, ROCKER SHOCK, M10 S/M GROUND CLEARANCE IRS
2	2	7972-2700	SUBFRAME CONNECTOR, S/M IRS M10 MUSTANG
3	1	5620-00	WELD ON CLIP, 64-70 MUSTANG, NO ENGINE SIDE MOUNTS, A-ARM, BARE
4	1	7962-5050	BODY OUTRIGGER, DRIVER, MUSTANG CLIP
5	1	7962-5051	BODY OUTRIGGER, PASSENGER MUSTANG CLIP
6	1	7972-2849	MEASURING TAB, BUMPER MOUNT, 9STREET M10 CHASSIS
7	1	3120-044S-Y	FLAT WASHER, 7/16 SAE, HARDENED, YELLOW ZINC
8	1	3100-044CI.00Y	HEX BOLT, 7/16-14 x 1, GRADE 8, YELLOW ZINC

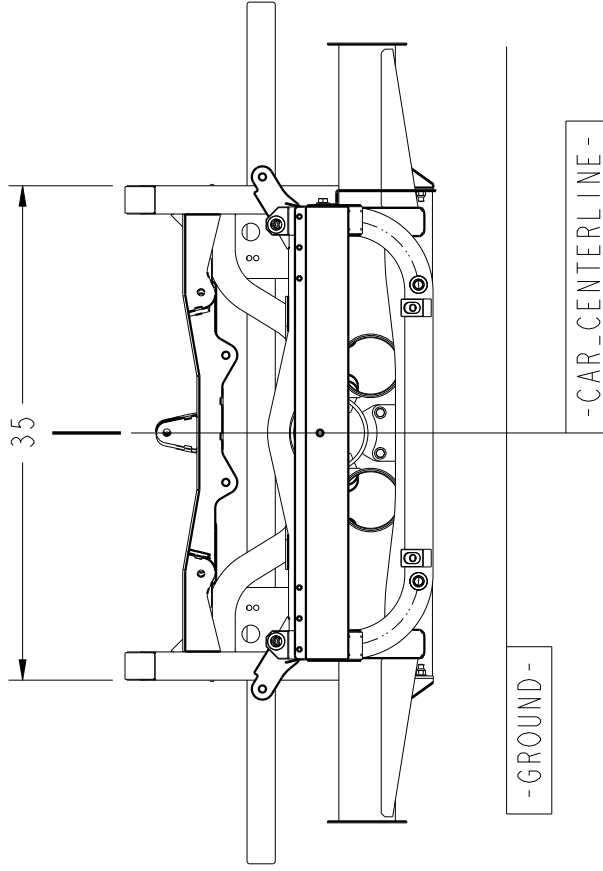

NOTES:

1. FRONT INNER FENDER LIP INSIDE WIDTH AT SPINDLE AXIS: 1965-66 67 1/2", 1967-70 68 1/4"
2. REAR INNER FENDER LIP INSIDE WIDTH AT REAR AXLE CENTERLINE: 1965-66 67 1/2", 1967-70 69 3/4"
3. ROCKER PANEL LOWER PINCH WELD SEAM LIP INSIDE WIDTH IS: 55 1/4"
4. B-PILLAR BODY SEAM BETWEEN DOOR AND QUARTER PANEL IS FORWARD OF REAR AXLE CENTERLINE 30" WITH 108" WHEELBASE

DESCRIPTION

**4 x 2 REAR FRAME,  
IRS, ROCKER, M10, 35 WIDE**

*Chris Alston's* **CHASSISWORKS INC.**  
8661 YOUNGER CREEK DRIVE  
SACRAMENTO, CA 95828  
(916) 386-0288 FAX 386-0286

PART NO.

**7723-M10**

6/1/20

DWG: 7951-7723M10

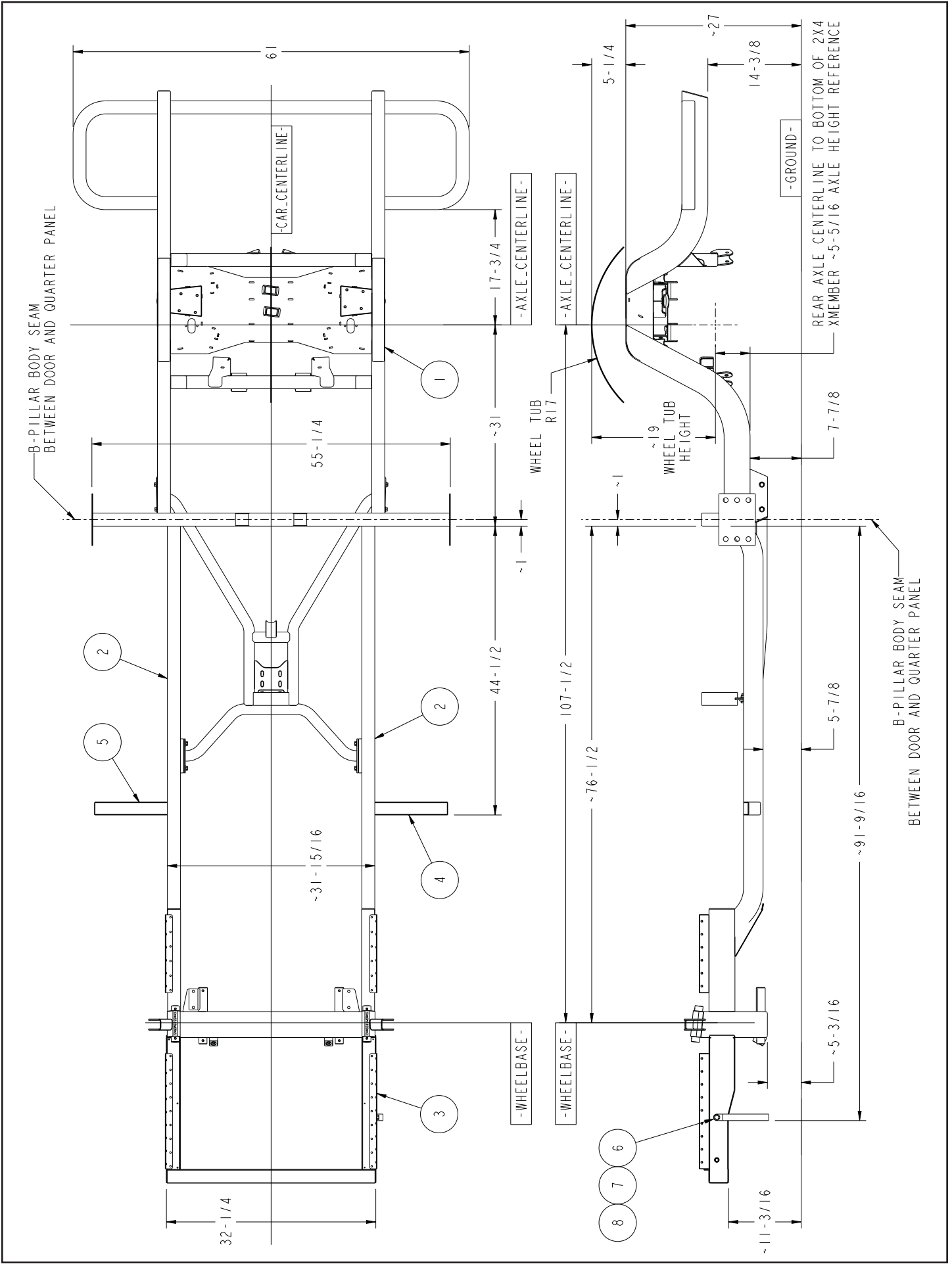

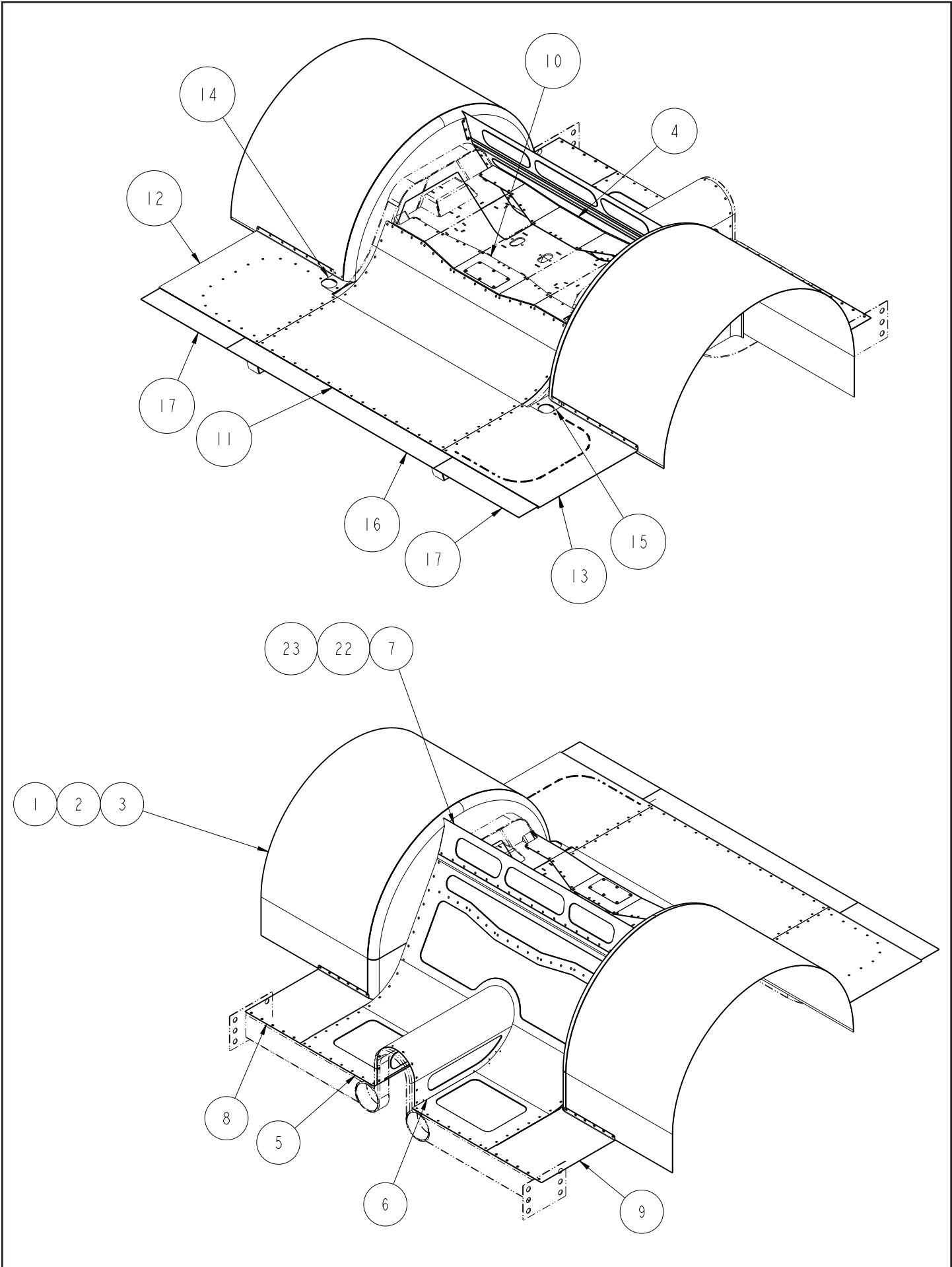

ITEM	QTY	PART NO.	DESCRIPTION
1	2	7972-2187	Ø34 WHEEL TUB CAP
2	2	7972-2193	INSERT, WHEEL TUB CORNER
3	2	7972-2191	SKIN, WHEEL TUB, Ø34 x 60 LONG, 3.30 STRAIGHT, 20 WIDE
4	1	7972-2481-35	FILLER PANEL, FRONT, IRS GEN2 CROSSMEMBER, 35 WIDE
5	1	7972-2495-35	REAR FLOOR, AXLE FRONT, IRS GEN2, M10, 35 WIDE
6	1	7972-2497	REAR TUNNEL TERMINATION, IRS, M10
7	1	7972-2659	BULKHEAD, REAR FIREWALL, IRS, M10
8	1	7972-2529	REAR FLOOR FILLER, FRONT AXLE, OUTBOARD PSGR, IRS, M10
9	1	7972-2530	REAR FLOOR FILLER, FRONT AXLE, OUTBOARD DRV, IRS, M10
10	1	7972-2482-35	FILLER PANEL, REAR, IRS GEN2 CROSSMEMBER, 35 WIDE
11	1	7972-2496-35	TRUNK FLOOR, IRS GEN2, M10, 35 WIDE
12	1	7972-2355	REAR TRUNK FLOOR, DRIVER, IRS, M10
13	1	7972-2356	REAR TRUNK FLOOR, PSGR, IRS, M10
14	1	7972-2498	FILLER, TRUNK, IRS, M10, DRIVER
15	1	7972-2499	FILLER, TRUNK, IRS, M10, PASSENGER
16	1	7972-2038	REAR FLOOR FILLER, TRUNK, CENTER, CANTED 4-BAR, F10
17	2	7972-2039	REAR FLOOR FILLER, TRUNK, OUTBOARD, CANTED 4-BAR, F10
18	1	7972-2375	COVER, RESERVOIR POCKET, IRS
19	6	3104-019F0.50S	BUTTON HEAD SOCKET CAP SCREW 10-32 x 1/2, STAINLESS STEEL
20	6	3157-019S-S	WASHER, #10 SAE, STAINLESS, 7/32 ID x .7/16 OD x 3/64 THICK
21	6	3101-019-32S	LOCKNUT 10-32, GRADE 5, STAINLESS STEEL
22	1	7972-2655	FILLER PLATE, REAR FIREWALL, DRIVER, CANTED 4-BAR, M10
23	1	7972-2656	FILLER PLATE, REAR FIREWALL, PSGR, CANTED 4-BAR, M10

DESCRIPTION		<b>4 x 2 REAR FRAME, IRS, ROCKER, M10, 35 WIDE</b>	
<i>Chris Aston's</i> <b>CHASSISWORKS INC.</b> 8661 YOUNGER CREEK DRIVE SACRAMENTO, CA 95828 (916) 388-0288 FAX 388-0295		PART NO.	<b>7723-M10</b>
		6/1/20	DWG: 7951-7723M10

# PARTS LIST

## 7723-M10 - Rocker-Arm IRS Frame Clip

Qty	Part Number-	Description
1	5907-34X21	Builder wheel tubs, 34" diameter x 21" wide
1	7950-7722M10R	Floor kit for IRS frame clip
2	7972-2409	Rear-crossmember rocker doubler plates
2	7972-2690-35	Rocker-Arm IRS frame clip, high ground clearance
2	7972-2849	Measuring tab, front bumper mount

## OPTION - Subframe Connectors

Qty	Part Number-	Description
1	7972-2700	3x2" frame connector (pair)
1	TCP SUBCS-02	Connector center support
1	7908-073	Drive shaft loop adjuster bracket
2	7908-074	Mounting block, 1-3/4 x 5-1/4"
1	7908-075	Center support mounting bracket, driver side
1	7908-076	Center support mounting bracket, passenger side

## OPTION - Exact-Fit Roll Bar

Qty	Part Number-	Description
1	4872-01-1-1	Main hoop 1-3/4" ERW (coupe)
1	4872-12-1-1	Rear strut, driver side (coupe)
1	4872-13-1-1	Rear strut, passenger side (coupe)
1	4872-01-1-2	Main hoop 1-3/4" ERW (fastback)
1	4872-12-1-2	Rear strut, driver side (fastback)
1	4872-13-1-2	Rear strut, passenger side (fastback)
2	4872-16-1	Side bar mild-steel 1-3/4"
1	7044	Back brace 1-3/4"
1	7045	Removable bent side bar 1-3/4"
1	E20.134-060.000	Tube 1-1/4 x .134 ERW x 60"
1	E28-134-060.000	Tube 1-3/4 x .134 ERW x 60"

# INSTRUCTIONS

The following photos may differ slightly from your vehicle depending upon year and body style. Installation procedures shown serve as a general guide. **Refer to assembly diagram for specific dimensions.**

## Leveling the Chassis

1. Level the body on the lift using the door sill rocker area for level placement. This is essential for following the dimensions given on the assembly diagrams.



## Cutting the Stock Floor

2. The stock floor must be removed. It is only required to cut from the forward edge of the B-pillar rearward to the tail lamp panel's lower structure.

IMAGE: We opted to extend our cut forward to the back edge of the seat platform. This requires fabrication of new rear foot wells or modification of replacement stock pans.



3. Wheel housings have been rough cut to more easily remove the floor. Floor panels are cut up to the rockers, leaving the rocker structure intact.



4. The stock wheel housings must be trimmed close to the quarter panel, while leaving the fender lip. A small piece of sheet metal can be used to protect the quarter panel when carefully cutting through the housing layer.



5. The stock wheel housing cleanly removed.



6. Any remnants of the rear floor along the rocker panel must be ground flush to allow the rear frame crossmember to seat.



7. The lip along rear quarter panel apron must also be cleaned up. Any sharp edges or burrs should be ground flush.



*With the rocker and quarter panel area finished, we can move on to the tail lamp panel.*

### Notching the Tail Light Panel

The bent panel below and inboard of the tail lamps requires notching to position the frame. The frame rails will extend through the lower panel.

8. Measure from each of the three tail lamp cutouts to find and mark the centerline (C/L) of each set. The tail lamp lens cutouts are not perfectly symmetrical and you will likely end up with three distinct centerlines. Average out a point between the farthest right and left centerlines and make this your tail lamp panel centerline.
9. Measure the rear frame clip to determine the inside and outside overall frame rail widths.
10. From the tail lamp centerline, measure and mark the position of each frame rail.

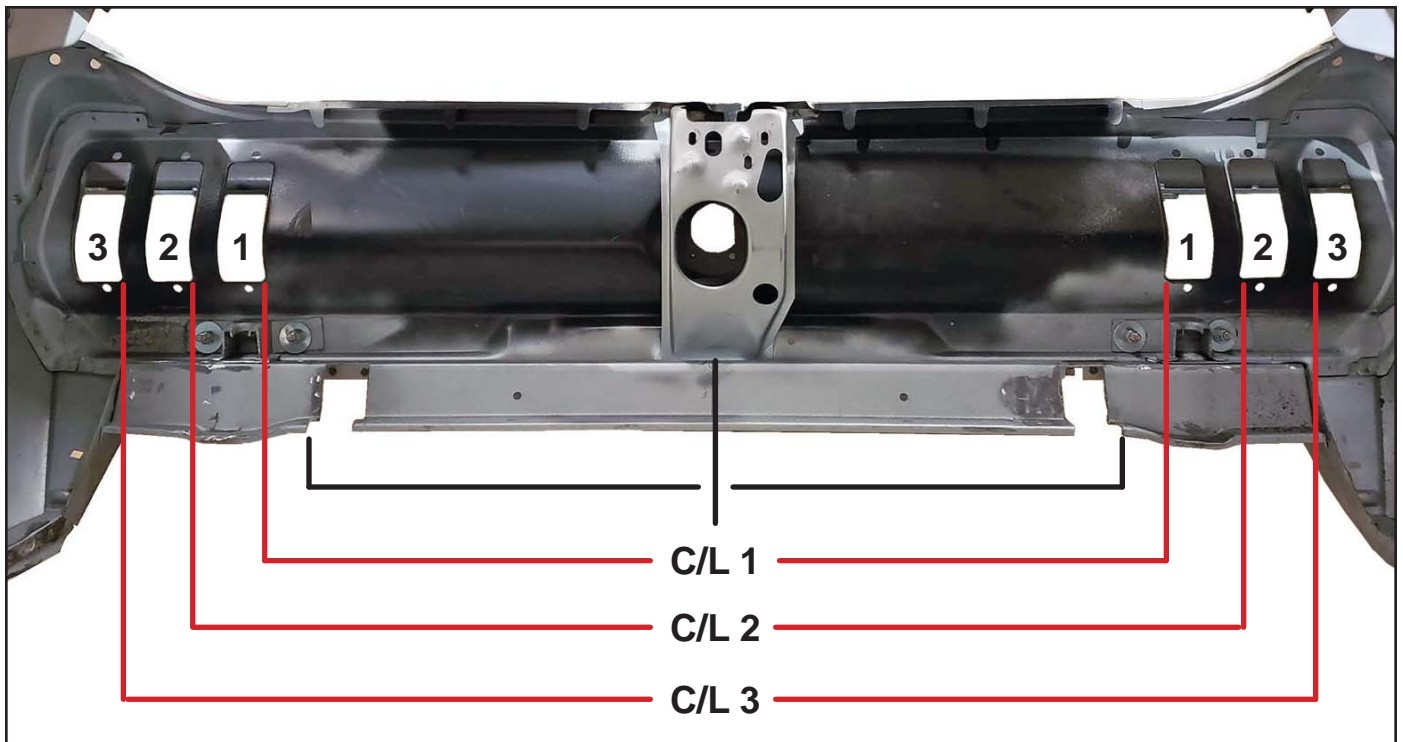

11. Cut the notches in the tail lamp panel 1/16" wider than the inside and outside of the rear frame rails; approximately 2-1/8" overall. Top of the notch must be flush with the top corner bend.

### Measuring for the B-Pillar Crossmember

To correctly position the rear axle within the wheel well and maintain the correct wheelbase we must establish a reference line that is relative to the front axle centerline. The 2x4" front crossmember of the rear clip is positioned using this reference line.

After measuring, reference marks are made along the bottom of the rocker panel to avoid measurement mistakes during final fitting.



12. First step is to position a straight-edge that runs the full width of the car under the rocker panels.
13. A spacer block with parallel surfaces is placed against the bottom side of the rocker outboard of the pinch weld seam.
14. A straight-edge material (angle stock or square tubing) is then clamped in place to sandwich the spacer against the rocker.
15. Use a small square to position the stack approximately 1" to 1-1/2" forward of the B-pillar door jamb seam. This is a good initial starting point for placing the straight-edge as the reference line will fall within this range.



16. Using the stock hardware, bolt the included measuring tabs to the rearmost bumper mount bosses. Securely tighten while using a level ensure the tab is perfectly vertical. Do this on both sides of the vehicle.



17. Measure from the front of the tab to the back of the straight-edge and position the straight-edge at the dimension shown on the assembly diagram.



18. The straight-edge position will be adjusted in the following steps. The square can be used to ensure the stack is flush.
19. The straight-edge can be tapped into position without unclamping. **Make sure the measuring tabs are square, clamps are tight and the stack is flush before re-measuring.**



20. This measurement and adjustment process is repeated multiple times, alternating from driver to passenger side until the straight-edge position matches the assembly diagram position.



21. With two accurate measurements and the straight-edge stack flush, score a line on the bottom of the rocker and outside of the pinch weld seam. This is our reference line to position the front edge of 2x4" rear frame crossmember.

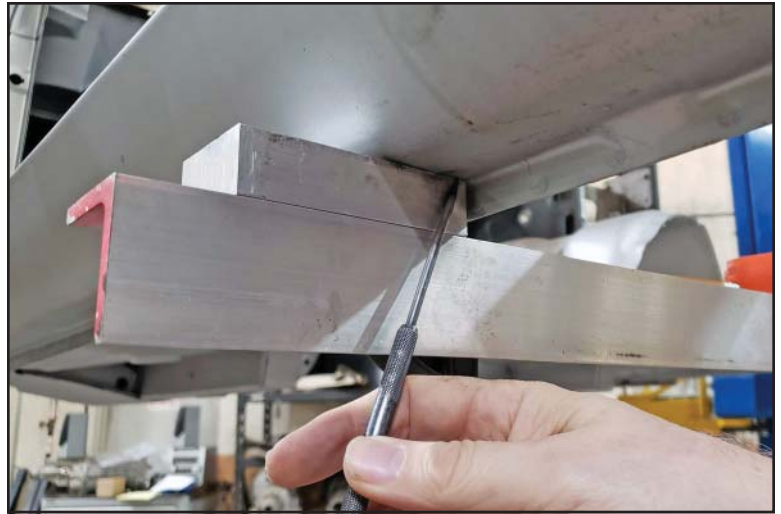

### Install Reinforcement Plates

22. Position the reinforcement plate flush with the bottom of rocker and centered 1" behind the "front-of-crossmember" reference line. See assembly diagram.
23. The plate feature holes for rosette welds, but we are initially tack welding during rear frame fitment.
24. After welding, scribe a line on the face of the reinforcement plate that lines up with the scribe line on the bottom of the rocker panel. This is the reference line for the front of the B-pillar crossmember.

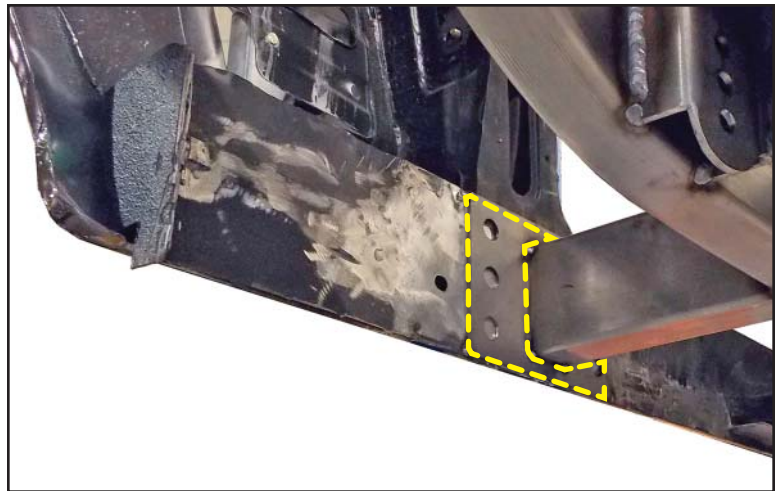

### Body Out of Square

OE manufacturing and chassis repair inconsistencies may cause the body to be out of alignment. When the frame clip is put into place, the crossmember distance to various points on the chassis will differ from the driver to passenger side. The distance to measuring tab is the primary dimension. We recommend splitting any difference (one side forward, one side behind the reference line) to minimize uneven wheel clearance and appearance within the wheel arch. Split difference is rarely more than 1/4" forward or 1/4" back of reference line.

It is extremely important that the rear frame remain as close to square and level to the front frame rails as possible in order for the vehicle to track straight. If necessary, the rear body at the tail lamp panel can be shifted to minimize the difference between driver and passenger side crossmember position at the rocker panels.

## Position Rear Clip In Body

25. The back end of the frame must be raised into position before bringing the front crossmember to meet the rocker panel. The ends of the frame rails pass through the tail lamp panel.



26. The rear valance will hide the frame rail ends when viewed from the rear.



27. The trunk floor will bridge any gaps between the rear crossmember and tail lamp panel.



28. Position the front edge of the crossmember even with the reference line on the reinforcement plate. Bottom of crossmember must be 1/2" above bottom of pinch weld seam.
29. Verify that the B-pillar seam to crossmember distance is between 1" and 1-1/2" on both sides. If the crossmember is outside of this range or differs significantly from side to side, there are several possible causes for the body being out of square.
- Incorrect measurement
  - Chassis not sitting level on lift (front-to-rear or right-to-left)
  - Improper vehicle repairs
  - OEM assembly tolerances



### Subframe Connectors

The optional full-length, dual-bend, 2x3" subframe connector can be installed a number of ways as needed to accommodate the forward portion of your chassis.

#### Full-Length Installation

As shown in the main chassis assembly diagram, the subframe connector can extend forward of the firewall to support the front subframe. The stock under-floor rail can be completely removed or the connector can be run between the walls of the stock rail. The connector should be attached to any OEM reinforcement structures, such as the tunnel brace or torque box.



#### Mid-Length Installation

As shown in the images to right, the subframe connector can be cut to a shorter length for integration into the stock rail. We recommend at a minimum extending the 2x3" connector to meet the forward edge of the stock tunnel reinforcement brace for better stability. The stock under-floor rail can be partially removed or the connector can be run between the wall of the stock rail as shown to right.



## Weld-In Transmission Crossmember

The optional weld-in, removable transmission crossmember (TCP MTC-U4) is highly recommended for the added flexibility in mounting position and greatly increased rigidity and strength.

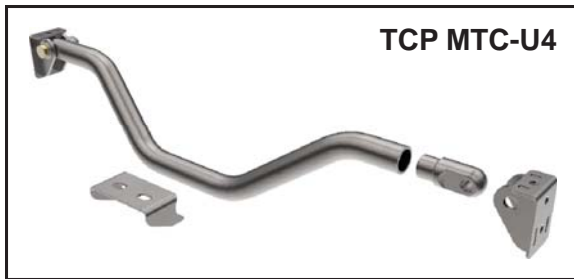

## FINAL WELDING

**Verify all dimensions against the assembly drawing before final welding.**

We recommend full fillet welds around all tubing attachment points. Sheet metal and reinforcement plates may be stitch welded along their outer edges. Many of our pre-fabricated panels feature holes for plug or rosette welds. Plug welds can be quickly ground flush using a coarse Scotch-brite wheel.

## Rear Floor

The rear floor can either be cut even with the front of the 2x4" crossmember or cut at the rear of the seat platform rearward.

**Removing the floor from the seat platform** gives better access for positioning the frame and welding to the rocker, but does require fabricating the rear section of floor.

**Retaining the stock rear floor** may create issues with fitting the rocker reinforcement plates and will require notching for subframe connector and exhaust clearance.

## Driveshaft Tunnel

Use Chassisworks driveshaft tunnel 5907-DST to meet the stock tunnel. Radius and width matches the crossmember loop. Trim to match slope angle and floor contour.



## Wheel Tubs

- **IMPORTANT:** Make sure wheel tubs are installed high enough in the body to allow full suspension travel.
- It is good practice to install the wheel tubs as high as possible. This allows for ride height or tire size changes.
- A separate wheel tub extension (5907-EXT) is available to extend the forward length of the wheel tub cap to seal against the frame. See placement in assembly drawing.
- **IMPORTANT:** Determine where the rear axle will be at ride height. This requires installing the front and rear wheels with tires to determine the body stance.
- Place the frame on blocks to simulate the desired ride height.
- Front shock ride height length is available in the shock's documentation.
  - Chassisworks front clips include a flat shock simulation tool to position the front suspension at the correct ride height.
- The rear shock ride height is 11.7" to 12.7" for 4.25" travel shocks.
- The designed ride height for the rear axle centerline is 5-5/16" above the bottom of the B-pillar 2x4" crossmember. *See drawing on page 7.*
- **After rear axle ride height is determined do the following calculation:**
  - **Divide the diameter of the mounted tire by two to find its radius.**
  - **Add four inches to the mounted-tire radius.**  
This is the minimum wheel tub height at top center (12 o'clock) above the rear axle centerline at ride height.
  - The standard wheel tub height at 12 o'clock above the rear frame clip 5-1/4" as shown on the drawing on page 7. Compare this to your calculated height to make sure you have enough tire clearance at full suspension compression with the tire size you selected.
  - *Failure to properly perform this step could result in having to install new wheel tubs.*



### WARRANTY NOTICE:

There are NO WARRANTIES, either expressed or implied. Neither the seller nor manufacturer will be liable for any loss, damage or injury, direct or indirect, arising from the use or inability to determine the appropriate use of any products. Before any attempt at installation, all drawings and/or instruction sheets should be completely reviewed to determine the suitability of the product for its intended use. In this connection, the user assumes all responsibility and risk. We reserve the right to change specification without notice. Further, Chris Alston's Chassisworks, Inc., makes **NO GUARANTEE** in reference to any specific class legality of any component. **ALL PRODUCTS ARE INTENDED FOR RACING AND OFF-ROAD USE AND MAY NOT BE LEGALLY USED ON THE HIGHWAY.** The products offered for sale are true race-car components and, in all cases, require some fabrication skill. **NO PRODUCT OR SERVICE IS DESIGNED OR INTENDED TO PREVENT INJURY OR DEATH.**

Chris Alston's Chassisworks  
8661 Younger Creek Drive  
Sacramento, CA 95828  
Phone: 916-388-0288  
Technical Support: sales@cachassisworks.com

