

**Independent Rear Suspension Frame Clip Systems  
 for Muscle Cars and Custom Installations**

- Complete system; frame, sheet metal, suspension
- True high-performance IRS system
- Tremendous cornering, acceleration, braking
- 1,500+ horsepower capable
- Fits 345/30R20 and larger
- Adjust caster, camber, toe
- Ride height (+/- 3/4")
- 4-way adjustable shocks (high-, low-speed)

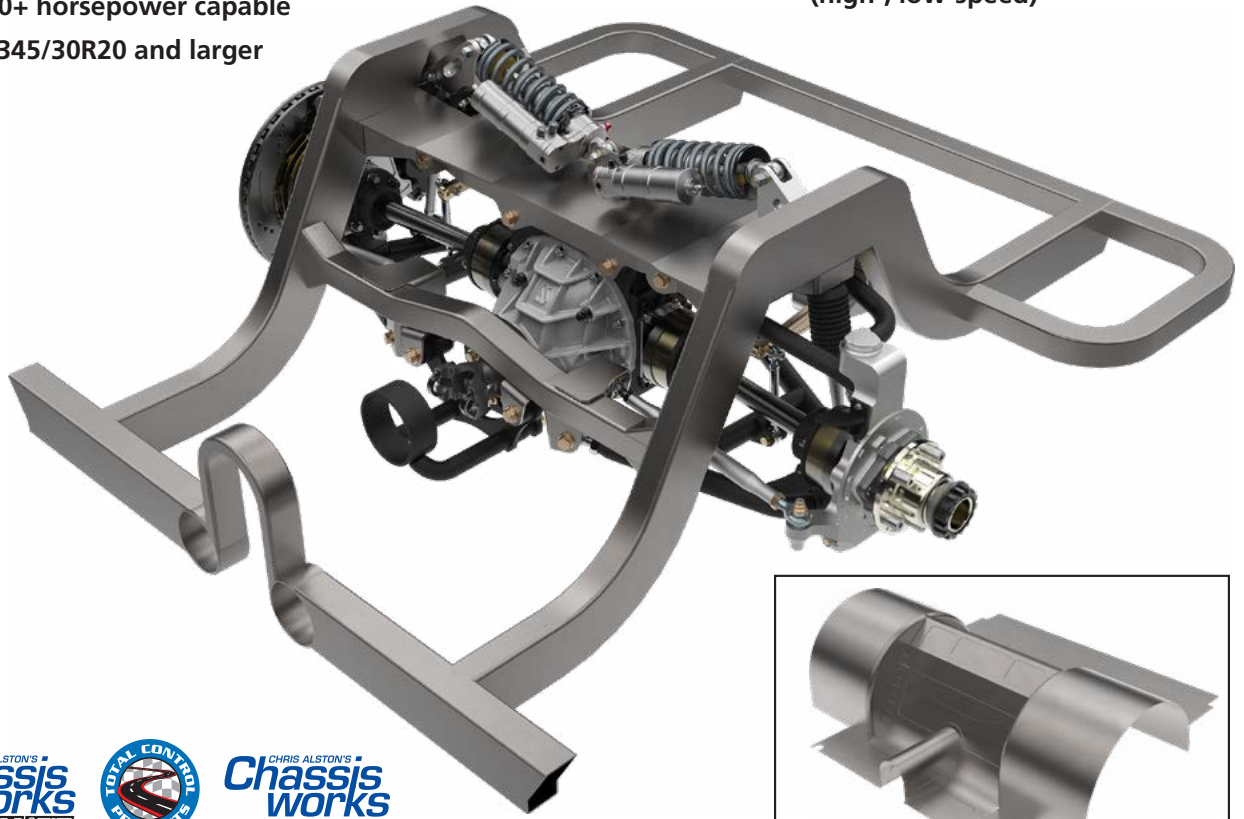

**Step up to the finest IRS available!**

Engineered and manufactured as a true high-performance independent rear suspension, the Chassisworks gStreet IRS is an exceptionally capable system intended for the most demanding high-horsepower, road handling applications. Offered as a replacement back-half or full-chassis system, the gStreet IRS is based upon a robust, mandrel-bent 4x2" frame clip with fully-boxed 2x2" suspension mounting crossmembers and fabricated upper cradle. The system features Chassisworks legendary FAB9 center section fitted with a series of six poly-bushing mounts to firmly hold the assembly, while reducing higher frequency vibration and road noise. The extremely stable center section and high-strength, 35-spline halfshaft assemblies are capable of dependably delivering over 1,500 horsepower. The suspension features rocker-arm-actuated coil-overs, which are mounted to the trunk floor, reducing unsprung weight. To ensure consistent

and correct geometry during hard cornering and acceleration, all suspension mounts are tied directly to the frame through use of Chassisworks exclusive TrueCenter pivot-ball assemblies. The deflection-free, low-friction joints are used in their double-shear configuration at the control arm to chassis mounts and the lower arm to spindle, while a pivoting-stud configuration is integrated directly into the upper end of the billet-aluminum upright. Less demanding pivot points at the toe links and anti-roll bar end links use equally precise, but smaller Teflon-lined spherical rod ends. Chassisworks gStreet is the premier option when selecting an IRS system and is currently available in four hub-to-hub widths (54, 56, 58 and 60") with **vehicle-specific chassis and floor kits for '67-81 Camaros, '64-72 GM A-Bodies and '64-70 Mustangs**. Custom-fit version also available for other vehicles.

# Frame Clip and Sheet Metal Packages

Chassisworks gStreet IRS system is made up of two component groups; the frame-clip sheet-metal package, and coil-over suspension systems.

- **Vehicle-specific packages**
- **Universal-fit packages also available**
- **Factory-welded frame**
- **Pre-formed sheet metal panels and tubs**

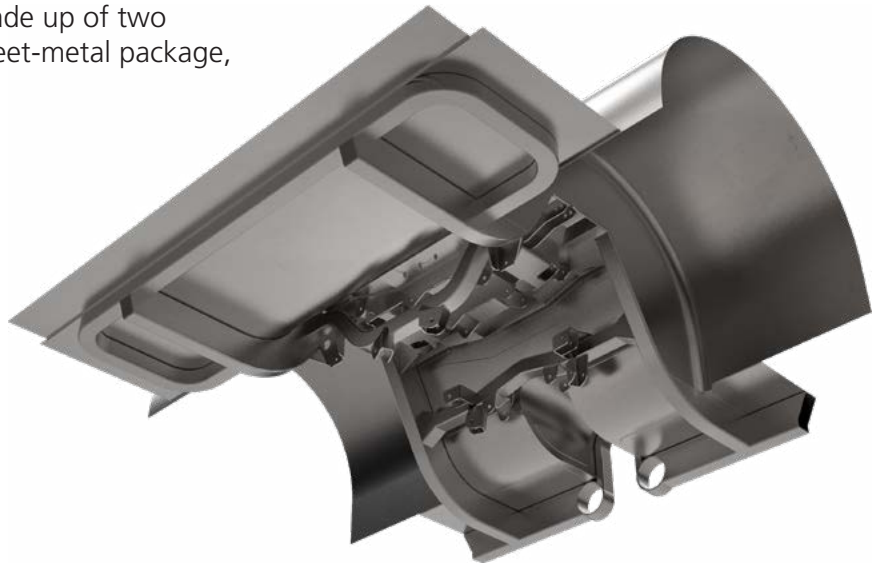

## Rear Frame Clip Assembly

Each frame clip is designed and manufactured with the intention of supporting extreme levels of acceleration, cornering and braking forces. The fully-boxed frame rails and crossmember, and broad fabricated upper cradle provide a durable, no-compromise structural platform. All components are manufactured using the latest CNC equipment and professionally welded by Chassisworks' staff in a controlled environment using computer-designed fixtures and production-quality equipment.

OPTIONS	3x2" subframe connectors
	Fabricated rocker supports
	Roll bar with back brace
	Roll cage (thru dash) with back brace
	Bolt-in side bars
NOTES	Includes factory-welded frame clip, rear floor and firewall, wheel tubs and truck floor. Suspension package not included.

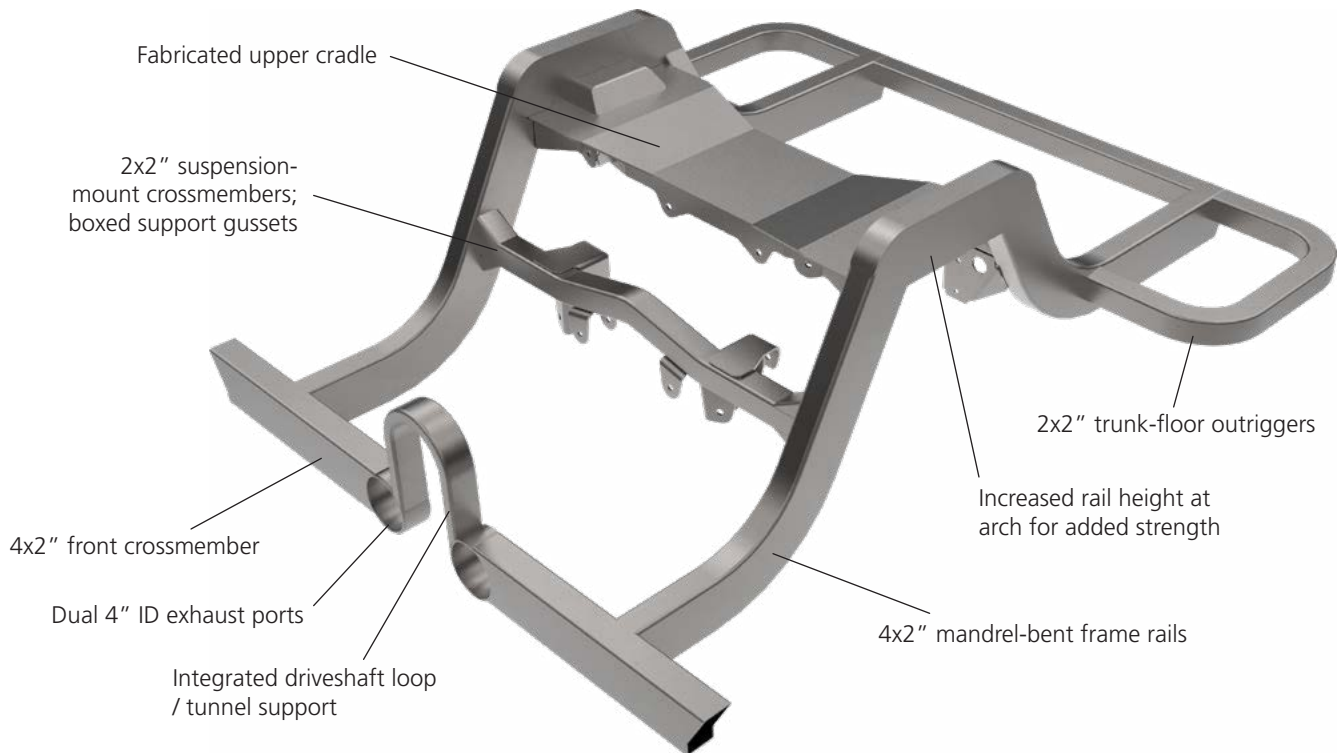

## Rocker-Arm-Actuated Coil-Over Frame Clips

Relocating the shock absorbers into the trunk area requires a pass-through hole with bellow boot-seal mount as well as chassis mounts for the billet-aluminum suspension rocker and fixed end of the shock.

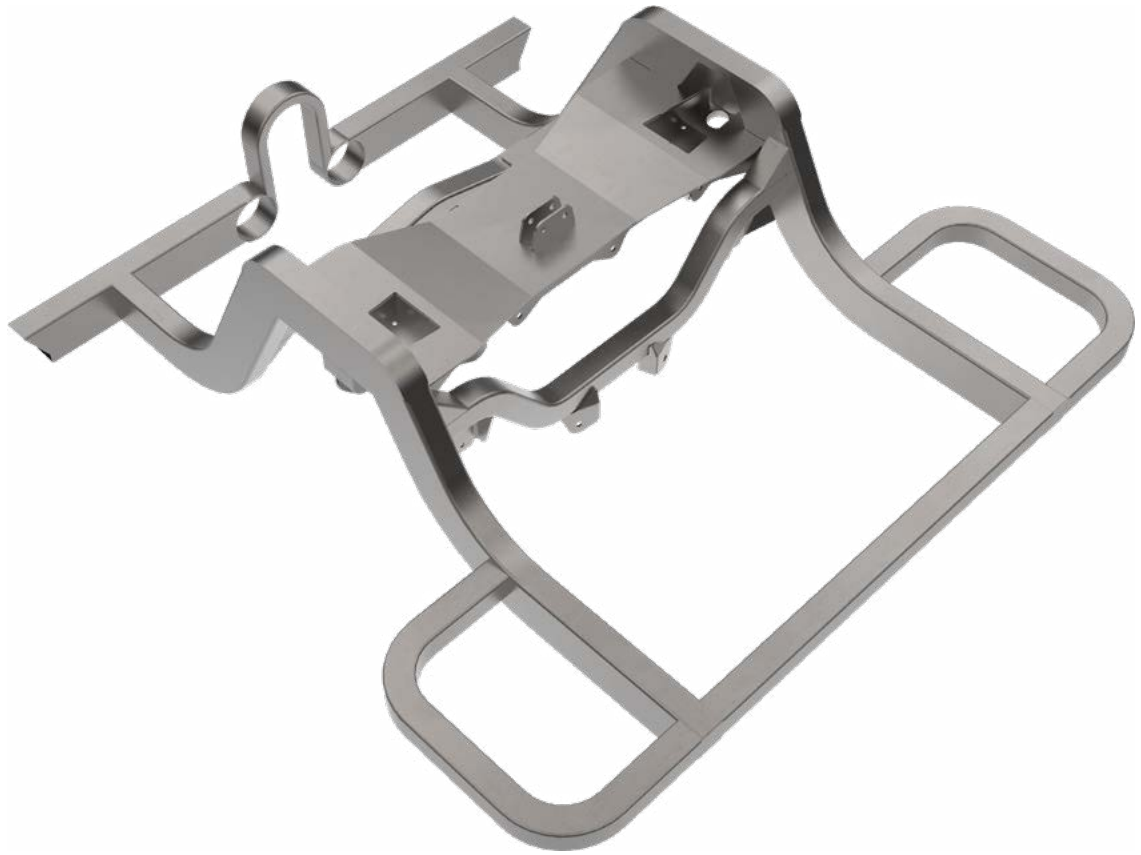

### Rocker-Arm Coil-Over Frame Clips

7723-A10	1964-67 GM A-Body
7723-A20	1968-72 GM A-Body
7723-F10	1967-69 Camaro, Firebird
7723-F20	1970-81 Camaro, Firebird
7723-M10	1964-70 Mustang, Cougar
7723-U01-W	Custom-Fit Applications
NOTES	Includes factory-welded frame clip, rear floor and firewall, wheel tubs and trunk floor. Suspension package purchased separately.

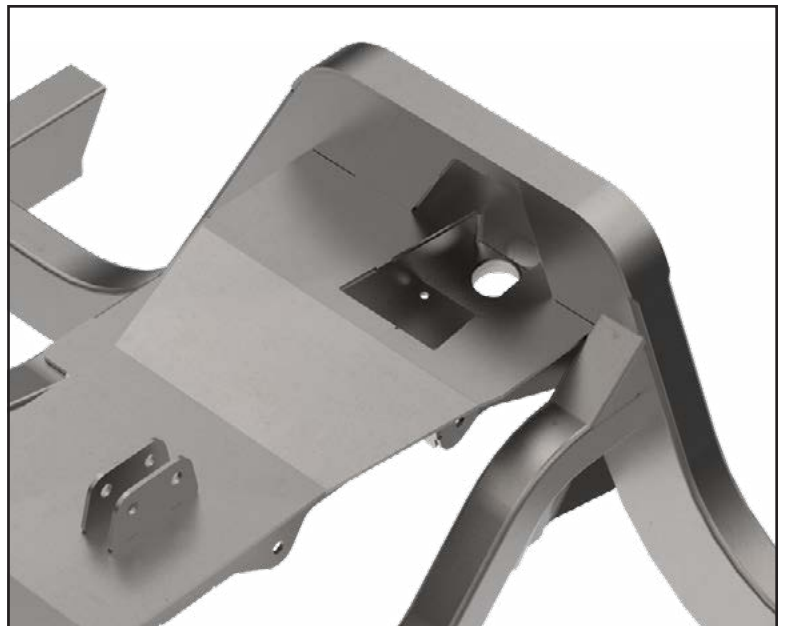

## GM A-Body Specific Frame Clips

<b>7723-A10</b>	'64-67 Rocker-Arm IRS Frame Clip
<b>7723-A20</b>	'68-72 Rocker-Arm IRS Frame Clip
INCLUDES	Frame clip (factory-welded)
	Floor kit, pre-fabricated (trim-to-fit)
	Builder wheel tubs
NOTES	Suspension package purchased separately



### Completing Your A-Body

The IRS frame clip may be used with direct-fit front suspensions or systems moderately below the stock ride height.

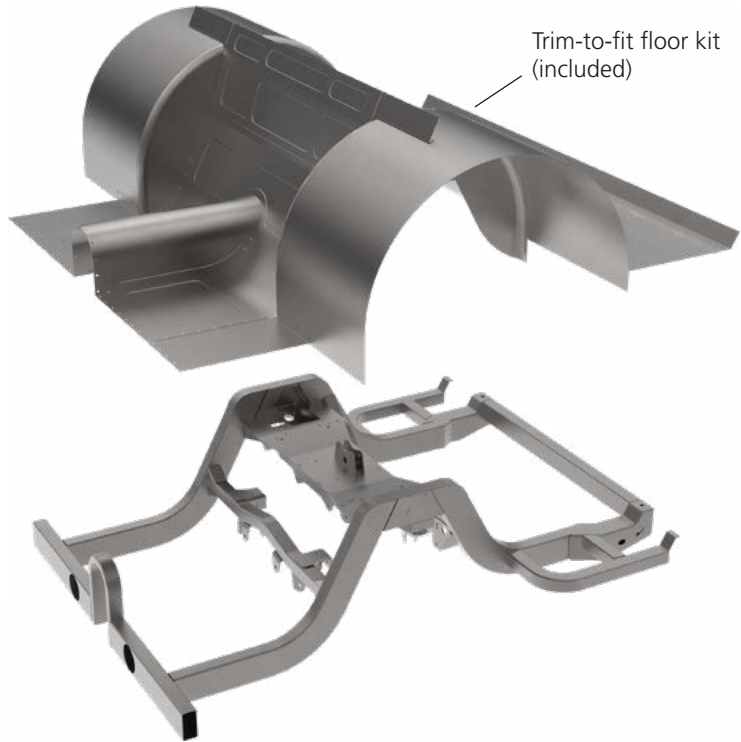

### A-Body IRS Chassis

The A-Body IRS system is also available as a replacement chassis, which includes complete firewall, floor and wheel tub tin kit.



## Camaro Specific Frame Clips

<b>7723-F10</b>	'67-69 Rocker-Arm IRS Frame Clip
<b>7723-F20</b>	'70-81 Rocker-Arm IRS Frame Clip
<b>INCLUDES</b>	Frame clip (factory-welded)
	Floor kit, pre-fabricated (trim-to-fit)
	Builder wheel tubs
<b>CONNECTOR OPTIONS</b>	Subframe connectors
	Boxed rocker supports
<b>ROLL BAR/CAGE OPTIONS</b>	Roll bar with removable back brace
	Roll cage with removable back brace; cage sides route through dash
	Bolt-in door bars
<b>NOTES</b>	Suspension package purchased separately

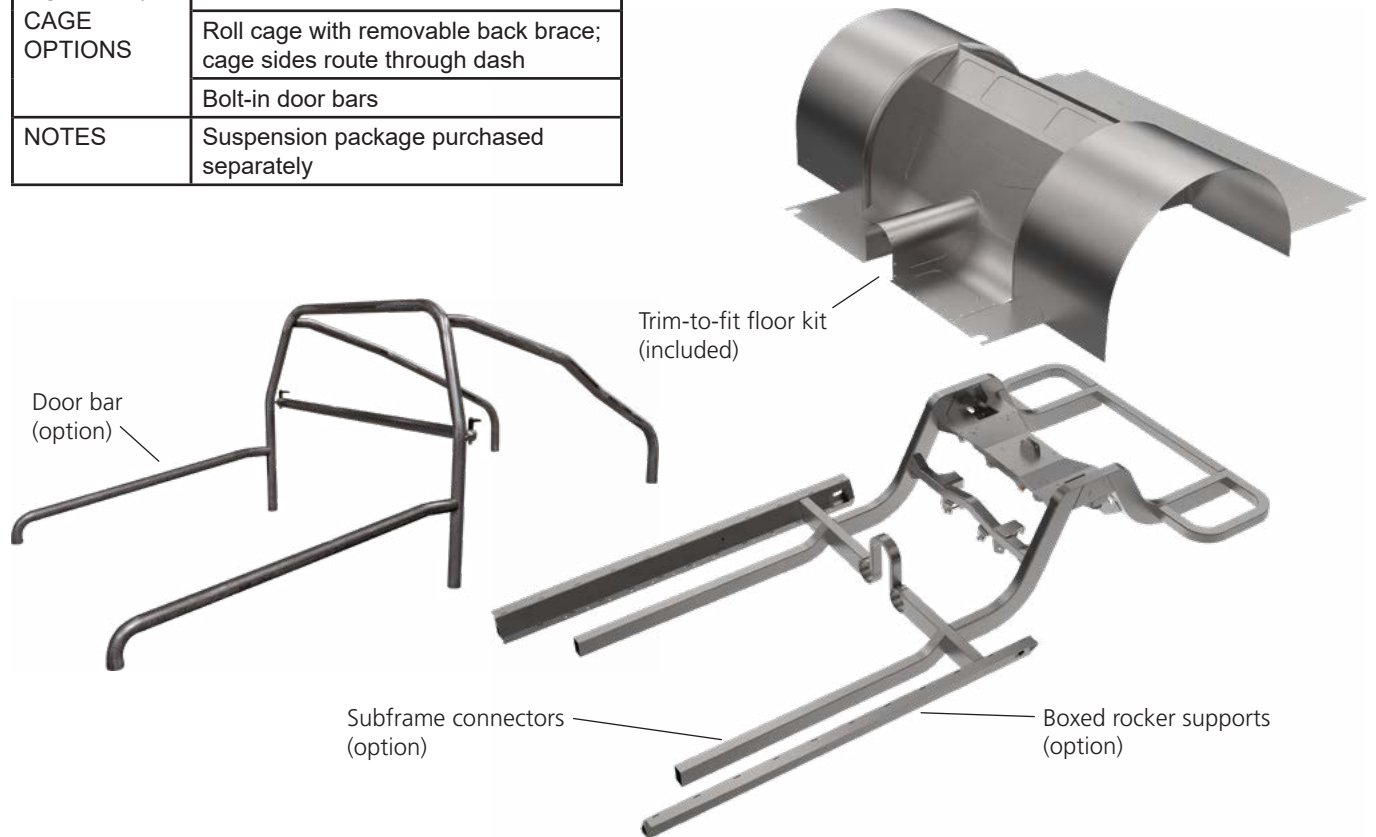

### Completing Your Camaro

The IRS frame clip, shown here with our Chassisworks bolt-on subframe clip, may be paired with direct-fit front suspensions or systems moderately below the stock ride height.



# Mustang Specific Frame Clips

<b>7723-M10</b>	'64-70 Rocker-Arm IRS Frame Clip
<b>INCLUDES</b>	Frame clip (factory-welded)
	Floor kit, pre-fabricated (trim-to-fit)
	Builder wheel tubs
	Front crossmember doubler plates
<b>CONNECTOR OPTIONS</b>	Mid-length 3x2" connectors
	Full-length 3x2" connectors
	Removable center support and driveshaft loop with weld-in mounting brackets
<b>NOTES</b>	Suspension package purchased separately

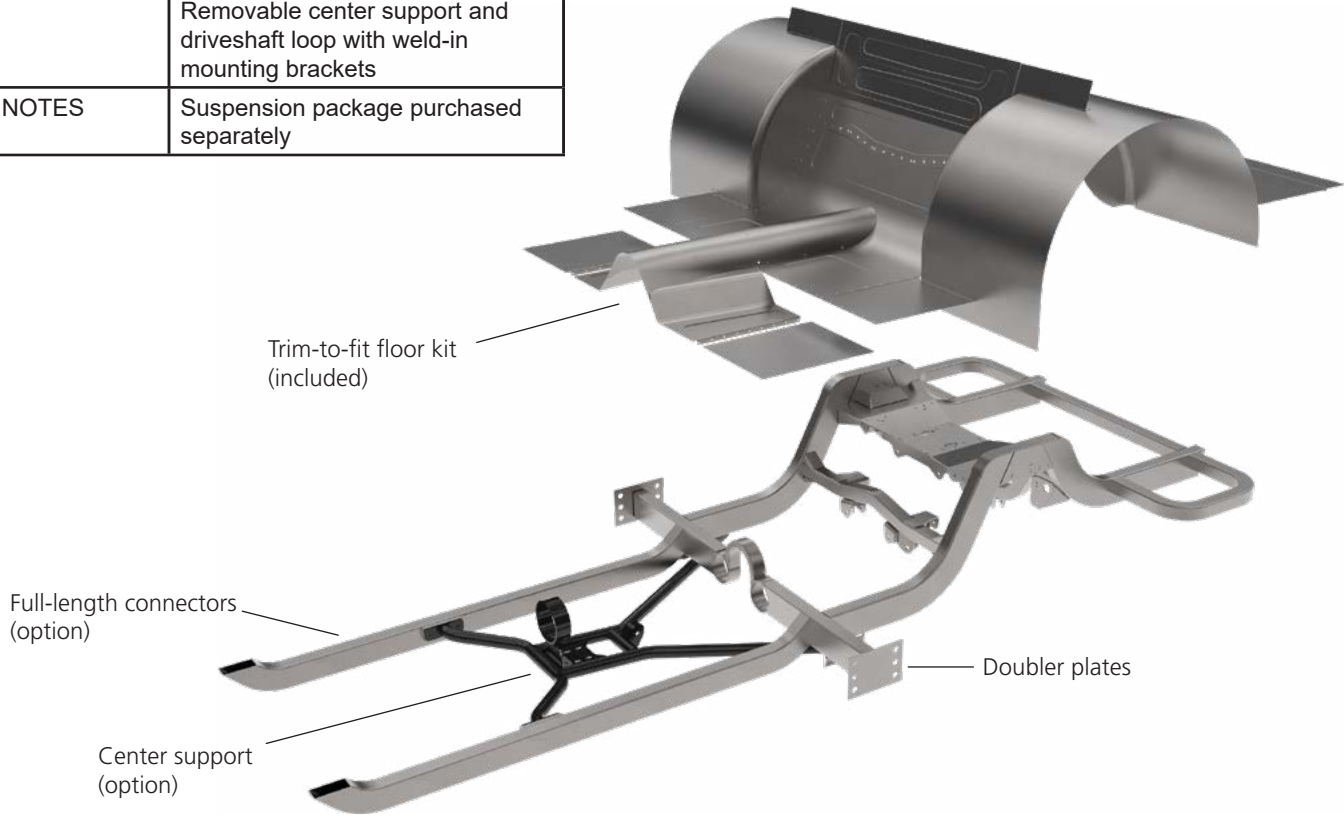

## Completing Your Mustang

The IRS frame clip, shown here with our Total Control Products front frame clip, may be paired with direct-fit front suspensions or systems moderately below the stock ride height.

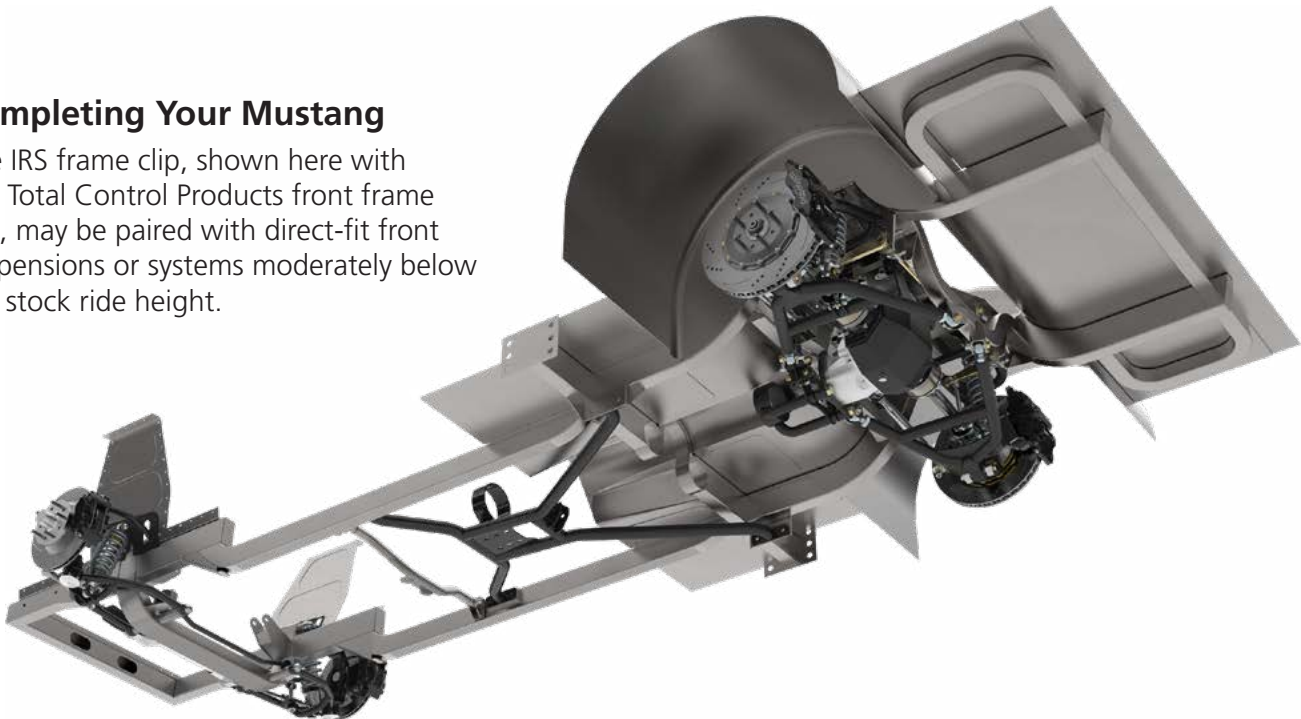

## Custom-Fit Frame Clips

<b>7723-U01-W</b>	Rocker-Arm IRS Frame Clip	
<b>5907-RIRS</b>	Floor kit, pre-fabricated (trim-to-fit)	
<b>5907-34X21</b>	Builder wheel tub, 34 x 21"	
<b>5907-40X25</b>	Builder wheel tub, 40 x 25"	
<b>5907-DST</b>	Driveshaft tunnel, 48" long	
FRAME OPTIONS	<b>Frame Width</b>	<b>Hub Width</b>
	35"	54"
	37"	56"
	39"	58"
	41"	60"
	Mid-length 3x2" connectors	
	Exhaust ports, 4" ID	
Full-length 3x2" connectors		
2x2" rear frame outriggers		
NOTES	Suspension package purchased separately	

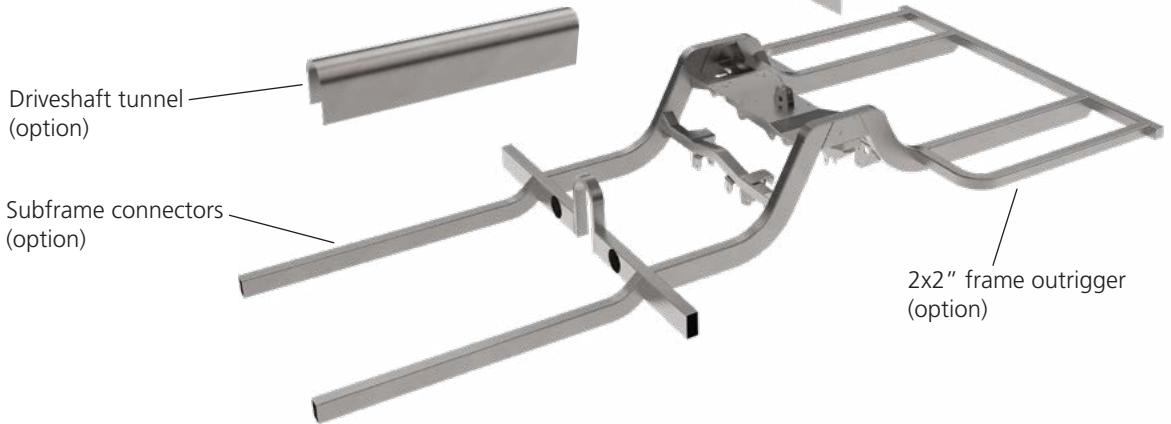
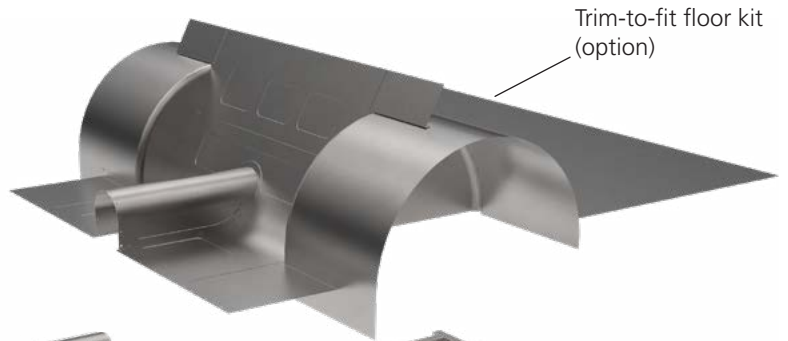

## Completing Your Custom Build

The custom-fit IRS frame clip can be matched with the complimenting Chassisworks A-Arm front suspension, available as a crossmember, front frame or complete custom-fit frame.

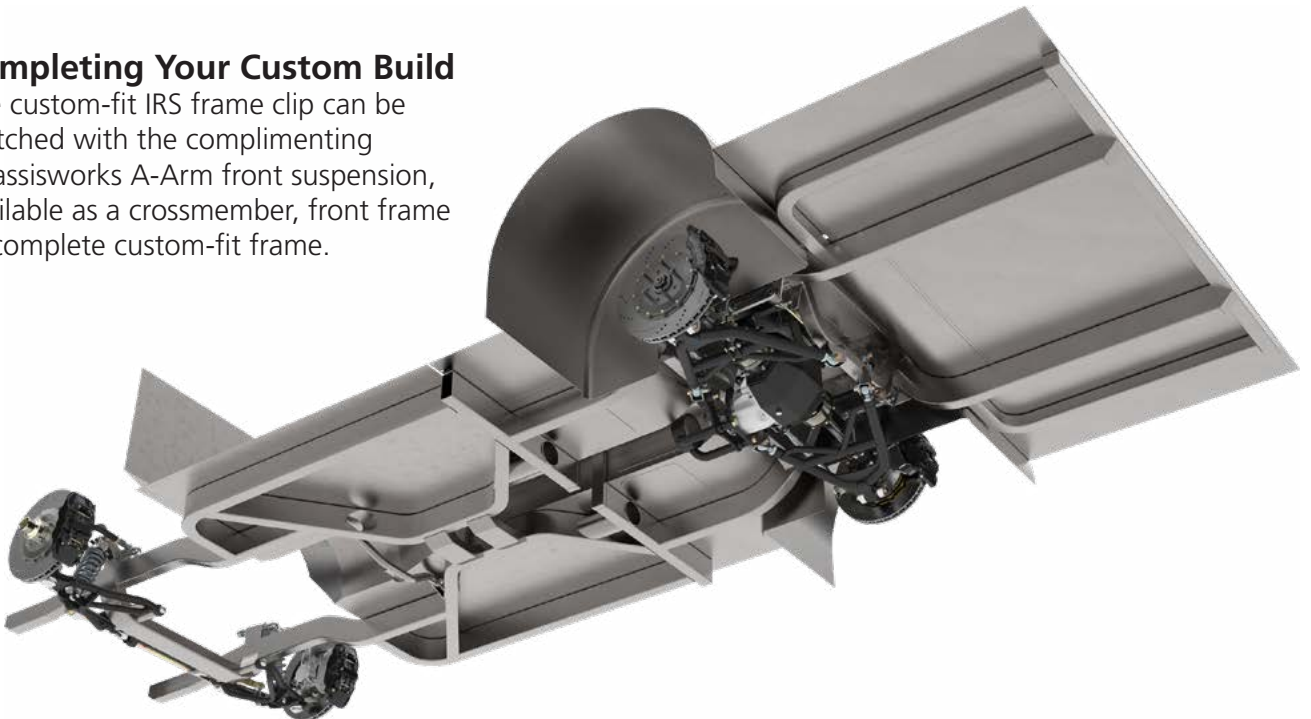

## Floor and Wheel Tubs Kit

The pre-formed and offset pocket rolled floor kit with wheel tubs saves hours of fabrication time. All components are 18-gauge cold-rolled steel and feature drilled or folded edges for easy fitment and welding. The kit uses Chassisworks builder-style wheel tubs, with large-radius corner and recessed lip for an extremely clean and finished appearance. Final fitment requires trimming to specific body contours.

Includes all components shown.

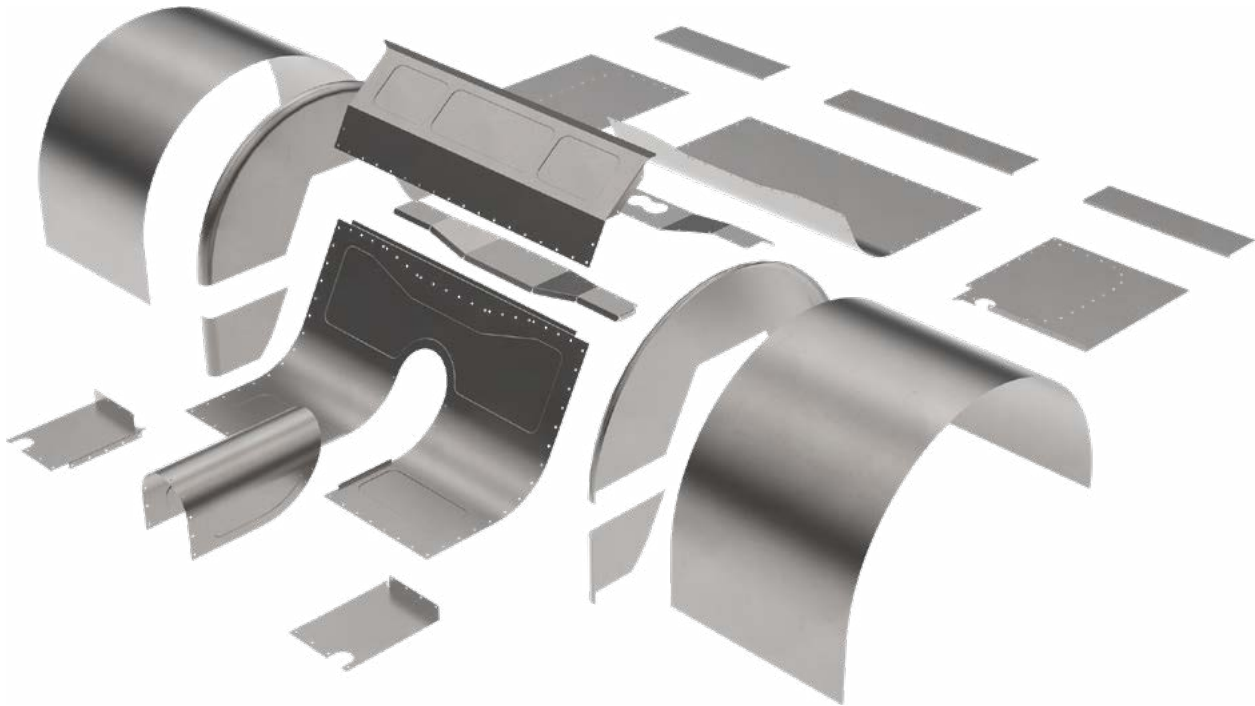
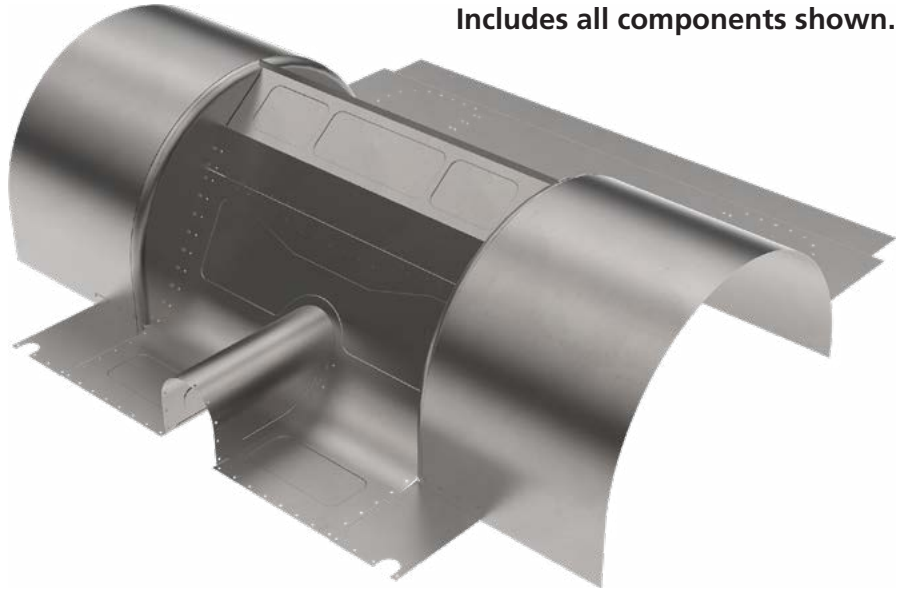

- 18-Gauge cold-rolled steel
- Smooth corner radius tubs
- Offset overlapped seam
- Fits 345/30R20 tires and larger

## Builder Wheel Tubs (also sold separately)

Designed for street or race car use, tub panels are made from 18-gauge (.050"-thickness) cold-rolled steel for improved durability and surface finish. End caps feature a 1"-radius corner with offset lip for easy assembly and flush outer surface alignment. Exterior welds can be ground flush for a completely seamless finish. Outer skins are shipped pre-rolled at the correct diameter for significantly easier assembly, with only light pressure needed when tack welding. Panels are shipped pre-formed with smooth surfaces, but can be bead rolled for added rigidity and custom appearance prior to assembly.

5907-34X21	Builder Wheel Tubs, 34"-OD x 21"-wide (pair)
5907-40X25	Builder Wheel Tubs, 40"-OD x 25"-wide (pair)
5907-EXT	End Cap Extension, 7" tall x 11" long (pair)

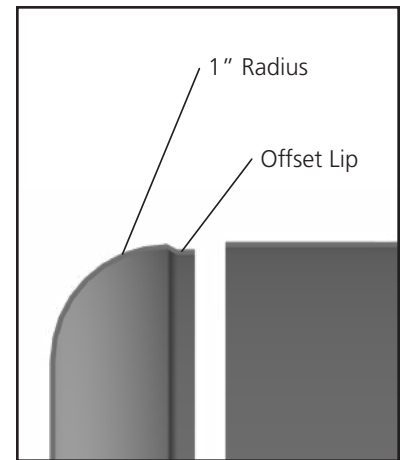

Offset tub-cap lip seats underneath edge of tub skin, creating an easy to align overlap joint with flush outer surface.

- Fits 345/30R20 tires and larger
- 18-Gauge cold-rolled steel
- Offset overlapped seam
- Smooth corner radius

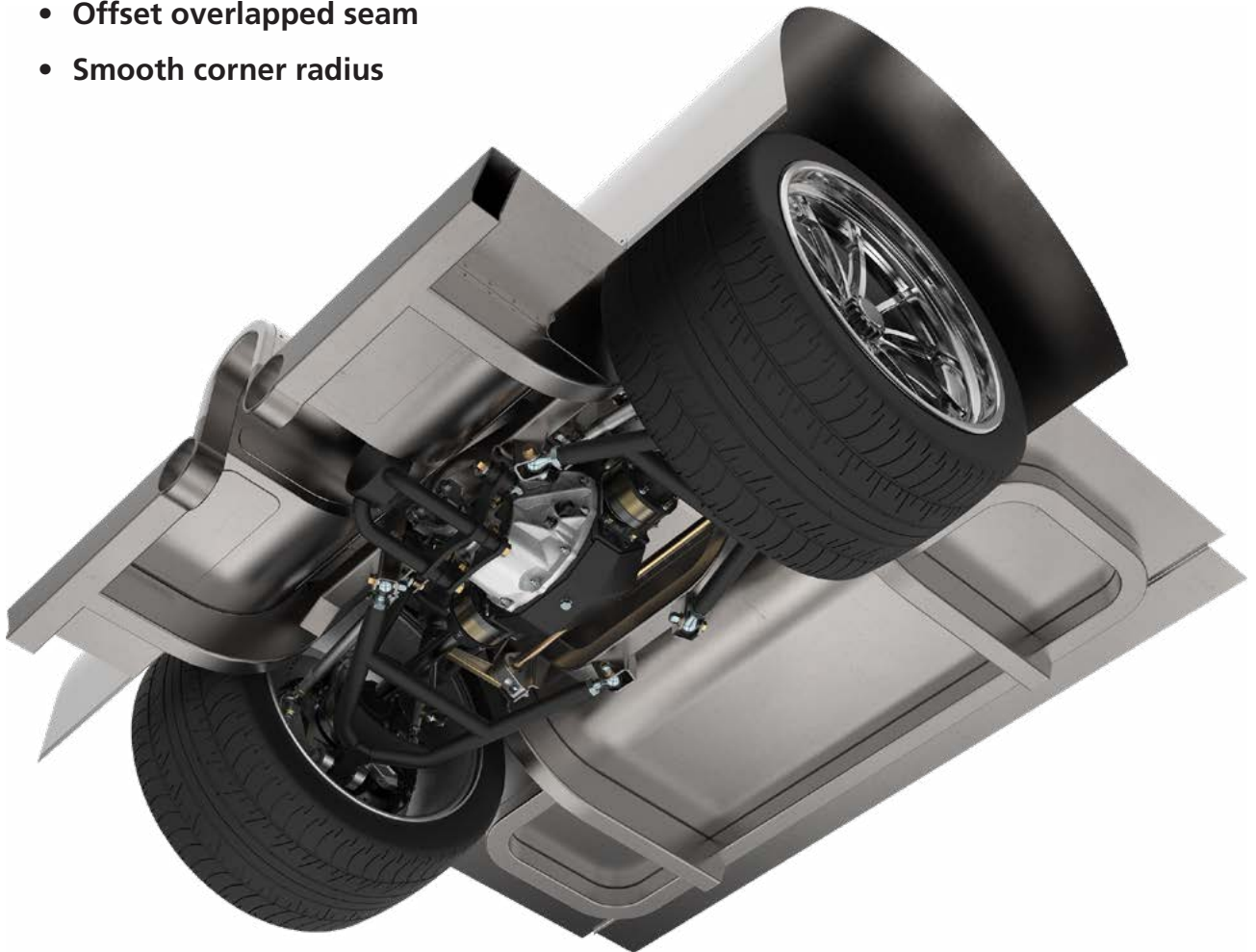

## Rocker-Arm IRS System (Coil-Over or Air)

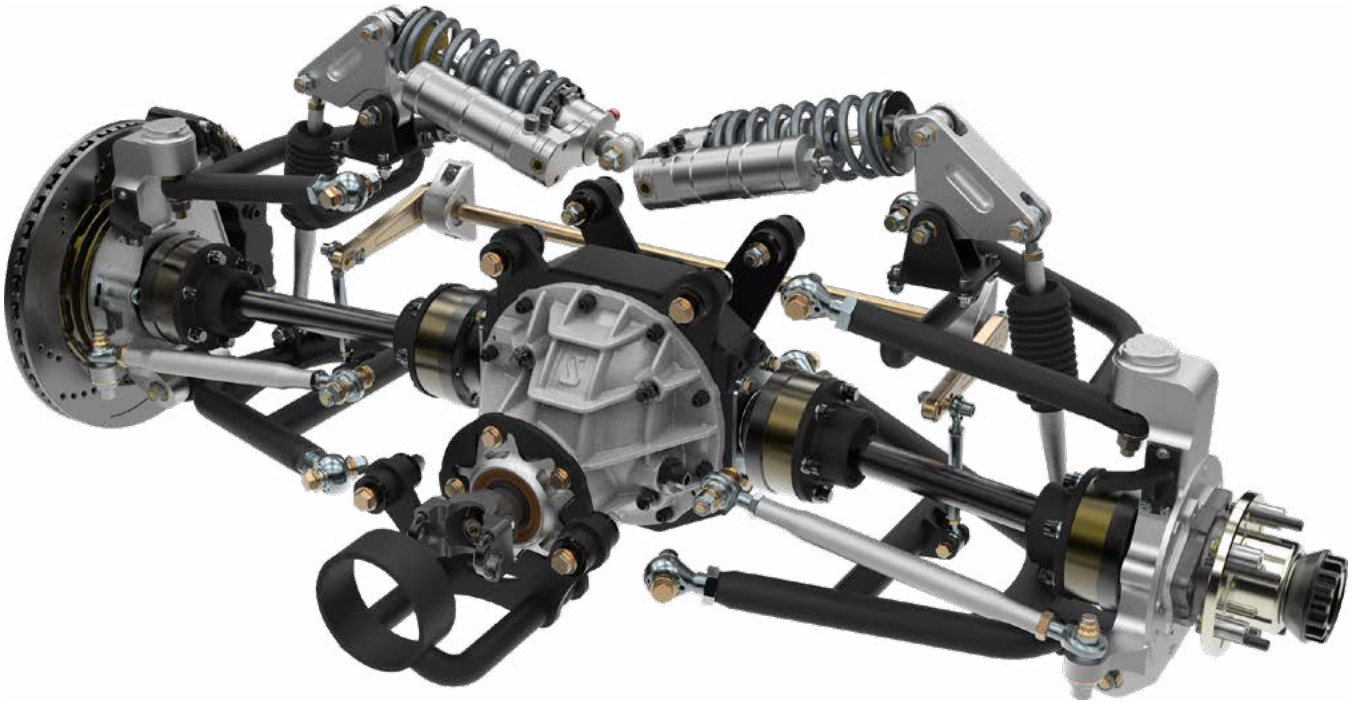

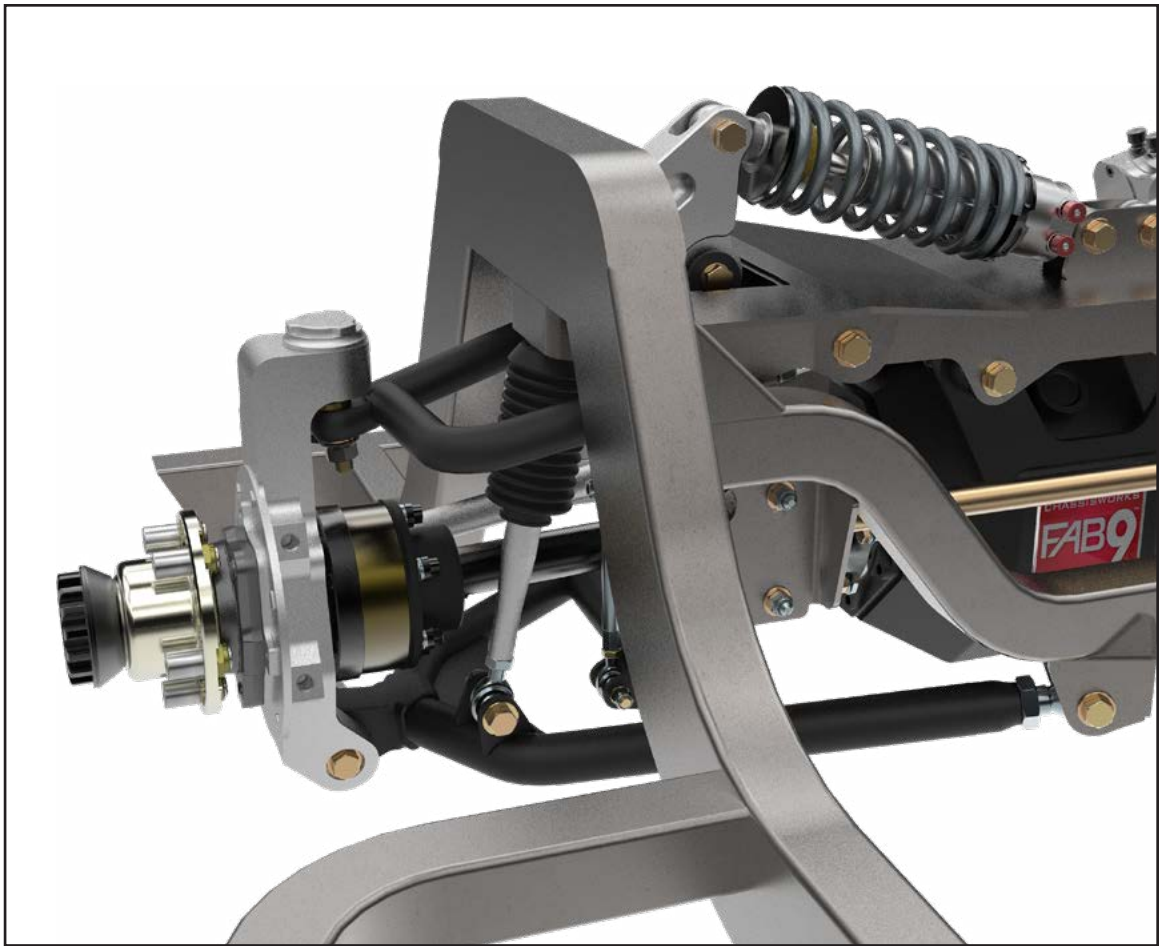

5867	Rocker-Arm-Actuated Coil-Over Suspension
OPTIONS	Hub-to-hub width (54", 56", 58", 60")
	Wheel bolt pattern (5 x 4-1/2", 5 x 4-3/4", center-lock long, center-lock short)
	Ring and pinion dropout style (Ford 9", Strange ST Iron, HD Pro Aluminum)
	Coil-over valving (single-, double-, 4-way adjustable with piggyback reservoir)
	Coil-over spring rate (450, 500, 550, 600 lb/in)
	Air-spring valving (single-, double-adjustable)
	Rear brakes (14" or 15" rotors, optional parking brake)
	Anti-roll bar (54", 56", 58", 60")
NOTE	Differential style (Strange S-Trac Helical, TrueTrac 35, Detroit Locker)
	Clip and sheet metal kit not included.

## gStreet Tubular Control Arms

Chassisworks' gStreet control arms are designed for ultimate-performance-handling vehicles using our gStreet IRS system with VariShock coil-over or air suspension. Spherical pivot-ball assemblies and cross-braced tubular design provide sharp handling and effective suspension tuning, thanks to minimal resistance and deflection. Mandrel-bent main

tubes and cross braces create an extremely rigid, triangulated arm durable enough for regular track use. With the aid of a fixture, tubes are seated into recessed faces along the billet receiver or balljoint housing to form a high-strength, interlocking, TIG-welded joint.

### Upper Control Arm

- Adjustable for caster and camber via threaded pivot-ball ends.
- Tension adjustable pivot-ball joints



**Upper Arm Pivot** - Housed within the billet upright, the tension-adjustable pivot assembly can be tightened to compensate for wear.

### Lower Control Arm

- Adjustable for caster and camber via threaded pivot-ball ends.
- Tension adjustable pivot-ball joints



**Control Arm Pivots** - Low-friction bearing races with tension adjustable spanner nut allow easy maintenance.

### Toe Link

- Adjust toe-in or out of rear wheel alignment
- Replaceable spherical-bearing rod ends
- Lightweight aluminum radius rod

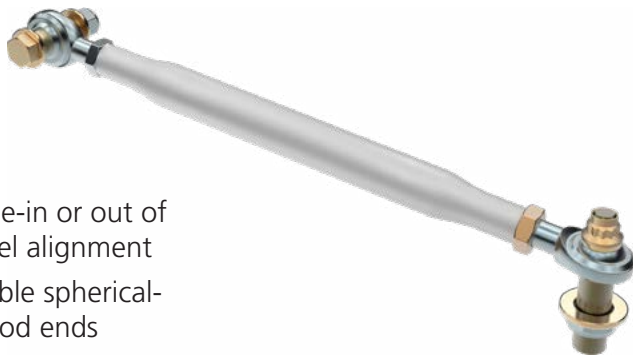

### Bump Steer Stud

- Threaded height-adjustable stud for exact tuning of toe-in or out setting



## Splined-End Anti-Roll Bar

The gStreet anti-roll bar features a 7/8" diameter, alloy-steel bar with splined attachment to billet-steel lever arms. Multiple endlink mounting holes allow six bar-rate adjustments to fine tune handling. Spherical-bearing endlinks attached to the control arms and provide adjustment to ensure zero preload. The combination of Chassisworks

polymer pivot, splined bar ends, spherical-bearing links, and rigid chassis attachment eliminates delayed resistance in the anti-roll bar system, common with rubber-, or urethane-mounted systems.



5861-S-088-2800	28"-wide bar assembly for 54" hub width
5861-S-088-3000	30"-wide bar assembly for 56" hub width
5861-S-088-3200	32"-wide bar assembly for 58" hub width
5861-S-088-3400	34"-wide bar assembly for 60" hub width
NOTE	Optional with suspension package purchase.



**Deflection-Free Mount** - The anti-roll bar mounts along the front side of the rear suspension-mount crossmember where it meets the frame rail. This is an extremely rigid area of the frame and eliminates any unwanted deflection under load.



**Deflection-Free Pivots** - The bar pivots on low-friction polymer bushings removing any freeplay from the bar to maximize control over suspension movement.

## gStreet Billet-Aluminum Upright

To best meet the requirements of our no-compromise design approach a purpose-built, feature-rich, billet-aluminum upright was engineered to provide superior rigidity and strength over the C6 spindle. Elements such as the steering arm, brake backing plate and upper pivot were integrated into the one-piece design. This created an overall broader component which provides consistent geometry control that is better suited to handle large tire, high horsepower applications under extreme cornering loads with exceptional reliability.

5864-A21-1	5 x 4-1/2" bolt pattern
5864-A21-2	5 x 4-1/2" bolt pattern
5864-A21-FC	Center-lock wheel
NOTE	Included with suspension package purchase.



**Five-Lug Flanges -**  
Available in 5 x 4-1/2" and 5 x 4-3/4" bolt patterns; 1/2-20 studs extend 2"



Forgeline center-lock style



- More rigid than C6 uprights for better geometry control
- Center-lock or 5-lug
- Low-friction upper arm pivot
- Radial-mount caliper and adapter bracket
- 4340 stub shaft
- Integral steering arm
- Double-shear lower arm clevis
- Threaded tie-rod arm for bump steer adjustment

## Tapered Unit-Bearing Hub

The heavy-duty bearing hub featured in Chassisworks floater axle system out performs the Corvette ZR1 hub as a result of its larger size and higher load capacity. Its opposing tapered-

roller-bearing design is better suited for extreme side loads, minimizing brake pad 'knock-back' and improving brake pedal consistency in high-performance applications.



1/2-20 studs extend 2"

## Bearing Hub Comparison



Chassisworks



Corvette



Chassisworks



Corvette

# Halfshaft and CV Joint Assemblies

- 35-spline 1-1/2" OD 4340 alloy-steel halfshafts and FAB9 stub shafts
- Race-duty 5" OD CV joints
- 4340 body, 300M cage and inner race
- 1/2" mounting bolts
- 1,500+ horsepower

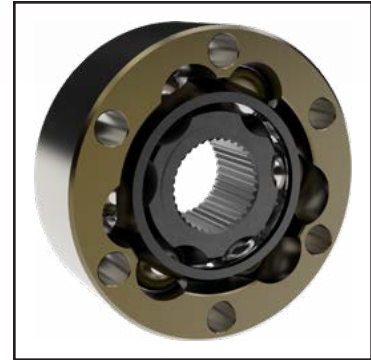

**5" OD CV Joints** - 35-spline 300M inner race and cage with 4340 body versus competitor's 4-1/4" OD 28-spline CV

Item Number	Overall Length
7963-AF35-1363	13.625"
7963-AF35-1463	14.625"
7963-AF35-1563	15.625"
7963-AF35-1663	16.625"
7963-AF35-1763	17.625"
7963-AF35-1863	18.625"

**NOTE:** Included with suspension package purchase.



**6-Different Lengths** - Halfshafts are available in multiple lengths to accommodate the four hub widths (54, 56, 58 and 60").

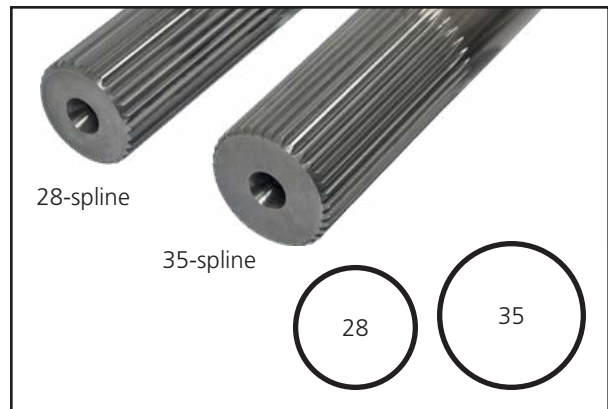

**35-Spline Shafts** - Larger diameter and greater spline count for significant strength increase over 28-spline axles.

## FAB9™ Ford 9" Center Section

gStreet IRS systems are fitted with Chassisworks legendary fabricated Ford 9" housing, FAB9™; for use with most 9" Ford style dropouts. This IRS version of the center section uses the familiar uniform-thickness outer housing panels, now with the addition of heavy-duty billet bearing-housing plates to properly support the 35-spline stub shafts.

Four individual bushing tabs extend from the top of the housing for attachment to Chassisworks IRS cradle or for simple mounting in custom installations.

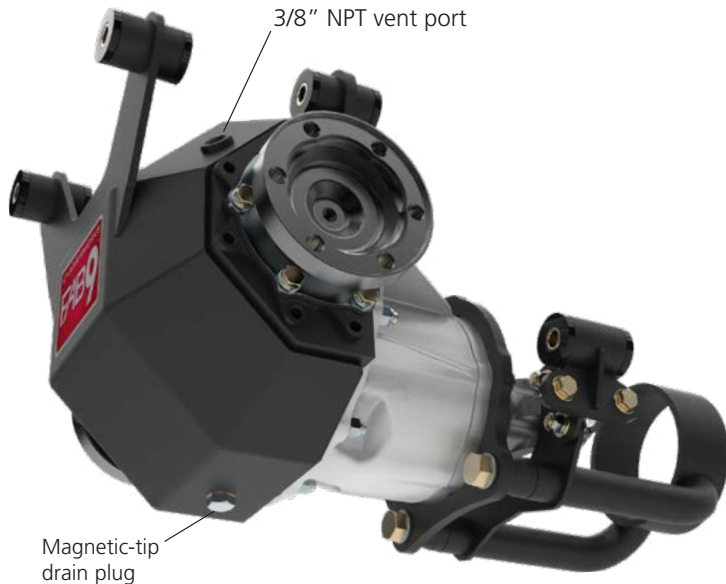

84150-N0C	FAB9 IRS center section with optional stub shafts and pinion support
NOTES	Included with suspension package purchase. Also sold separately for custom installations.
	Nine-inch dropout must be purchased separately.



## Pinion Support (Superior Mount)

Poly-bushing mounts located along the top of the FAB9 housing and pinion support structure secure center section assembly to the upper cradle and front suspension crossmember. Capturing the pinion bearing support adds two additional mounts that significantly broadens the grip on the center section without reducing ground clearance.



S-Series, Pro-Iron, OEM  
(smooth bore support)

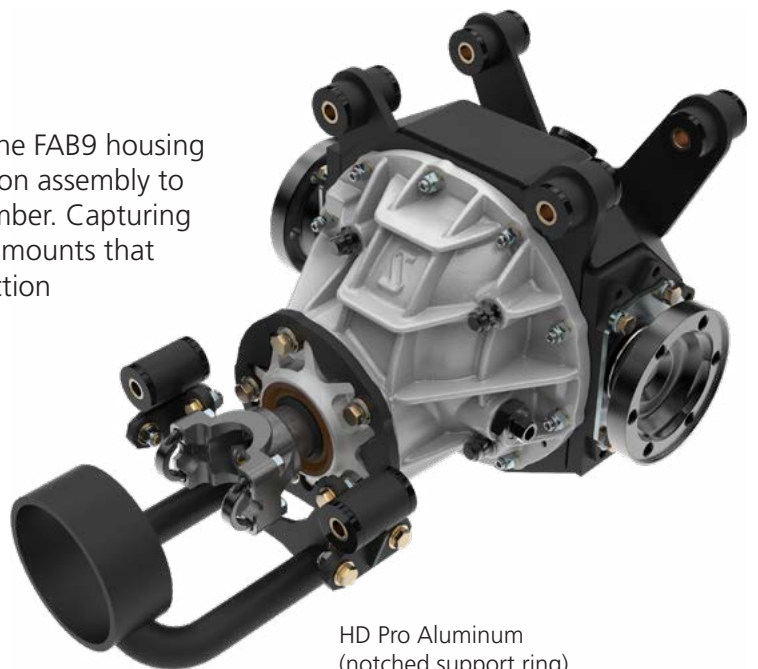

HD Pro Aluminum  
(notched support ring)

## VariShock Coil-Over and Air-Spring Shocks

Delivering a finished product that is of excellent quality and value is the primary focus throughout the VariShock product line. Unlike other brands in this price range, VariShocks are engineered, manufactured, and assembled in America using state-of-the-art engineering workstations and computer-numeric-controlled (CNC) manufacturing equipment. Each component, including valves, adjusters, and internal shaft seals is designed and manufactured specifically for use in VariShock products. This level of clean-sheet engineering is the first step to producing longer lasting seals that keep dirt out of the shock absorber and extend service life between rebuilds.

### Select Your Performance Level

We offer the broadest range of shock options of any manufacturer, allowing detailed custom configuration of your complete suspension system.

- **QuickSet 1 (QS1) - Single 16-position knob adjusts bump and rebound simultaneously**
- **QuickSet 2 (QS2) - Dual 16-position knobs adjust bump and rebound independently**
- **QuickSet 4 Remote (Q4R) - Gas-pressurized remote-reservoir or piggyback version provides independent high- and low-speed adjustment for bump and rebound**

### QuickSet 1 and 2 Shock Valving

VariShock's QuickSet, adjustable, design is easy to tune: 16 different settings are attainable simply by rotating the fully accessible, positive click knobs. Knobs are laser-etched with directional arrows and "plus/minus" symbols that clearly indicate which direction achieves the desired adjustment. Adjustments are made in seconds, without removing or unbolting the VariShock. QuickSet 1 shocks use a single knob to simultaneously set bump (compression) and rebound (extension) characteristics. QuickSet 2 double-adjustable shocks are available as an upgrade to enable separate 16-position bump and rebound adjustments.

### QuickSet 4 Shock Valving Remote or Piggyback Reservoir

The VariShock Q4R remote or piggyback reservoir shock separates the bump and rebound valve mechanisms between the two units. Four 16-position knobs provide high- and low-speed adjustment of bump and rebound independently.

**Piggyback-Reservoir**  
Used with rocker-arm-actuated shock

**Remote-Reservoir**  
Used with control-arm mounted shock



Part Number	Style	Valves	Ride Height	Compressed	Extended	Shock Travel	Mount Eye
VAS 11111-515	Coil-Over	Single	13.53"	10.95"	16.10"	5.15"	COM-8
VAS 11211-515	Coil-Over	Double	13.53"	10.95"	16.10"	5.15"	COM-8
VAS 11411-50	Remote	4-Way	13.31"	10.81"	15.81"	5.00"	COM-8
VAS 115X11-5	Piggyback	4-Way	13.31"	10.81"	15.81"	5.00"	COM-8
VAS 131K2-515	Air-Spring	Single	14.06"	11.56"	16.56"	5.00"	Poly
VAS 132K2-515	Air-Spring	Double	14.06"	11.56"	16.56"	5.00"	Poly

## High-Travel VariSprings

The new VariSpring line of springs was designed to complement the VariShock family. Once again, we used higher technology to resolve application limitations. These springs are manufactured using a new, ultra-high-tensile wire, which is stronger than the chrome silicon wire used by other manufacturers. This allows the springs to "set solid." The springs can compress until the coils touch without damaging the spring or causing it to take a set, which ultimately changes the ride height. Since this wire can flex more than conventional wire, these springs have greater travel than our competitors' springs of the same rate. These springs will allow your shocks to travel their full range of motion without going solid. This gives you greater traction and control at full bump, plus additional suspension travel for tuning. If you are ready to take advantage of higher technology with greater travel, lighter, stronger springs, then step up to VariSprings. VariSprings have a silver-powder-coat finish.



## Spring Rate Selection

Spring rate affects ride quality, ride height, roll rate, and performance handling characteristics. Differences in vehicles such as aluminum engine components, vehicle weight distribution, fiberglass body parts, chassis stiffening as well as wheel-size and offset and the specific performance application, should be taken into consideration. Additional tuning springs are available at a discount when purchased with a system.

## VariShock Accessories

### Spanner Wrench

Also available is an exclusive spanner wrench, incorporating four tangs, which will not slip off the lower spring seat because it engages the seat in four places (not one, like common spanners).



899-012-201

### Coil-Over Spring Compressor

The VariShock coil-over-spring compressor greatly eases lower-spring-collar adjustment on high-preload or high-rate applications. Heavy-duty plates at each end fit 2-1/2" inside-diameter coil springs of 130 lb., rate or greater, with a maximum spring height of 14".

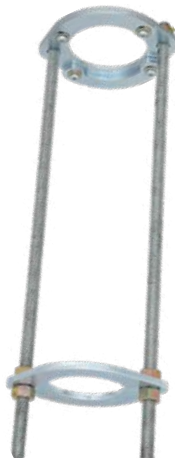

VAS 200

### Spring-Seat Thrust Bearings

Thrust bearings are used at the lower spring seat to reduce friction when adjusting ride height. New stainless "cap-style" seats, a VariShock exclusive, enclose the thrust bearing to keep dirt out.



VAS 513-100

## gStreet Brakes for Billet Uprights

gStreet brake kits for Chassisworks IRS feature radial-mount, four-piston calipers, and 14" or 15" directional-vaned rotors with billet aluminum hats. The complete brake kit features an internal, drum-style, parking brake mechanism. The bolt-together hat-rotor-drum assembly allows worn or damaged components to be replaced easily and economically.

Enhanced-friction ceramic-formula brake pads provide smooth engagement, long service life, low noise, and light brake-dust levels for performance driving applications; performance specific pads

are also available for autocross and road race applications. Fourteen- and fifteen-inch rotors require 18" and 19" wheels respectively.

8383-14	14" disc brake kit for 5-lug hub
8383-15	15" disc brake kit for 5-lug hub
8384-14	14" disc brake kit for center-lock hub
8384-15	15" disc brake kit for center-lock hub
OPTION	Wilwood Aero 4, Baer 6S, Baer 6P calipers
NOTE	Includes calipers, pads, directional-vaned rotors (1.25" thick), billet caliper bracket, internal drum-style parking brake

