

**READ ALL INSTRUCTIONS COMPLETELY AND THOROUGHLY UNDERSTAND THEM BEFORE DOING ANYTHING.  
CALL CHASSISWORKS TECH SUPPORT (916) 388-0288 IF YOU NEED ASSISTANCE.**

## **INSTALLATION AND TUNING GUIDE**



**VAS 161MS-425**

### **Bolt-In Front Coil-Over Conversion Single-Adjustable - QuickSet 1**



### **Shock Mounting Specifications**

Part Number	Valving	Mounting		Total Travel	Compressed Length*	Extended Length*	Ride Height*		Spring Length
		Upper	Lower				Min.	Max.	
VAS 161MS-425	Single	Spherical Stem	Crossbar	4.25"	10.27"	14.52"	11.97"	12.82"	9"

\* Shock mounting lengths are measured from the chassis contact surface of upper stem to pivot center of crossbar. Add .20" to lengths if measuring to control arm contact surface of lower crossbar.

# PARTS LIST

Prior to beginning installation use the following parts lists to verify that you have received all components required for installation.

## VAS 161MS-425 - VariShock QuickSet 1 Coil-Overs

Part Number	Qty	Description
8A14XAX-43EA	2	QuickSet 1 Coil-Over Shock, Upper Stem and Short Lower Poly Mounts
3173-09-20-32	2	Bumpstop 1-1/4" long
899-020-208	2	Ball-Stud Top Mount Hardware
VAS 501-103	1	Spring Seat Set, Extended 3/4"
3102-056-18RC	2	Jam Nut 9/16-18 RH, Clear Zinc
899-061-304	1	Crossbar Hardware Bag
899-012-HEX7/64	1	Ball-End Driver 7/64" Hex Screw

## 899-020-208 - Ball-Stud Top Mount Hardware

Part Number	Qty	Description
3117-063-18C	1	Half Locknut 5/8-18 Nylon Insert
3144-25-28-0	1	Grease Zerk 1/4-28 Straight
899-044.63-1.13	1	Washer .635" ID x 1.13" OD, Zinc-Plated Steel
899-044.70-1.25	1	Washer .695" ID x 1.25" OD, Zinc-Plated Steel
899-060-201	1	Ball-Socket Stud Assembly

## VAS 501-103 - Spring Seat Set, Extended 3/4"

Part Number	Qty	Description
899-002-200	2	Lower Spring Seat with Assembled Ball Locks
899-002-204	2	Upper Spring Seat, Extended 3/4"

## 899-061-304 - Crossbar Hardware Bag

Part Number	Qty	Description
3100-038C1.75Y	4	Bolt 3/8-16 x 1-3/4" Hex Head
3101-038-16C	4	Locknut 3/8-16 Nylon Insert
3163-10F2.88B	2	Stud 5/8-18 x 3", (preinstalled in crossbar half)
3120-038S-Y	8	Washer 3/8" Flat SAE, Hardened
3140-2024-040	2	Sleeve 5/8" ID x 3/4" OD x 1-1/4" long
3141-2436-0.61H	4	Poly Bushing .75 ID x 1.125 OD, Flanged
3151-5ML	1	Poly Lube, 5ml Tube
899-042-4.66	4	Crossbar (E-2), 4.39" to 4.66" Bolt Centers

# INSTRUCTIONS

## Shock Assembly - Lower Crossbar

Open the 899-061-304 hardware bag and remove the parts shown. These items will be used to assemble the crossbar.

1. Using a 5/8-18 tap, chase the threads of the crossbar half that does not have the preinstalled stud.

If the stud is not preinstalled, chase threads on both crossbar halves.

Put red loctite on shorter threaded end and screw into one crossbar half until 2.05 to 2.13" of stud sticks out past the crossbar face.



2. Press two bushings into each shock eye.



3. Grease the inside of the bushings.
4. Press the sleeve into the bushings.



5. Place the crossbar half with the preinstalled setscrew in the vice.
6. Set the shock, with sleeve installed, over the setscrew.
7. Use a crescent wrench to screw the crossbar halves together until the assembly stops at the sleeve. You will feel a noticeable stop.



8. **CLOCKING STEP:** Tighten the assembly to the very first evenly-clocked position (less than one-half turn). Bring the crossbar into position in small increments and verify its position at each step; clocking it in one motion risks overtightening. A straightedge should be placed against the exposed crossbar tab to tell if the tab is in line with the vice jaws.



9. Once the tabs are correctly clocked, the shock crossbar assembly can be rotated perpendicular to the shock body as shown.
10. The shock is ready for the spring to be installed.



# Tools and Accessories

The following items are available from the Chassisworks' product line, or local auto parts or hardware retailer.

**VariShock Spring Compressor** – Recommended to aide installation of heavy-rate springs onto shocks and ease lower spring-seat adjustment.



VAS 200

**VariShock Spanner Wrench** – Non-slip four-tang spanner wrench designed specifically for leveraged adjustment of VariShock lower spring seats.



899-012-201

**VariShock Thrust Bearings** – Installs between the spring and lower seat to allow the spring to twist freely during preload adjustment and normal operation.



VAS 513-100

**Anti-Seize Thread Lubricant** – Reduces friction and chance of thread galling during preload adjustment.

## Bump Stops

VariShock shocks and struts, and ShockWave air springs come equipped with a standard bump ring or pad to prevent harsh impacts when the shock bottoms out. The standard bump ring (see image) is a light-duty bumper and should not be subjected to repeated or severe contact. To better protect the shocks from it is best to install a chassis-to-axle housing (at the rear) or a chassis-to-control arm (in the front) hard-rubber or urethane bump stop. VariShock also offers a progressive-rate foam-construction bump stop for use on shock absorber and strut piston shafts. In addition to softening the impact the foam bump stop progressively increases the effective spring rate, avoiding an instant shift to an infinitely stiff rate that can severely alter how the vehicle handles. It is important to remember that all bump stops are a service part and need to be replaced if worn. Their service life will vary considerably based on the frequency and how hard they are used.



Standard VariShock Bump Ring



Standard VariStrut Bump Stop



Progressive-Rate Foam Bump Stop

# VariSpring Installation

1. Prior to spring installation, all shocks must be test fitted on the vehicle to verify there is no binding and a minimum of 1/2" of clearance around the shock and spring throughout the full range of suspension travel.
2. Verify the travel length of your coil-over shock by fully extending the shock and measuring the distance from the top of the reservoir to the bottom of the jam nut under the top mount eye. Ignore any travel reductions caused by bump stops. Your shock travel should measure 4.25"
3. Verify the free length of your coil spring. Your spring length should measure 9".
4. Adjust the threaded lower-spring-seat setscrew locks by unscrewing them so that a single thread is visible.
5. Apply anti-seize to the inside threads of the lower spring seat.
6. With the spring-seat spanner-wrench notches facing toward the shock base, place the spring seat over the top eye and piston shaft, and thread it onto the shock body as far as it will go without hitting the adjustment knob(s).

**NOTE:** After final spring seat adjustments have been made, tighten the setscrews to lock the lower seat in place. Always make sure the threads on the reservoir body are clean of any dirt before adjusting the spring seat.

**DO NOT adjust the lower spring seat without first jacking up the car to remove the vehicle's weight from the spring; even with spring-seat thrust bearings installed.**

7. Install optional spring-seat thrust bearing onto the shock lower spring seat at this time. Bearings must be lightly greased prior to installation.
8. Place the coil spring over the top eye and piston shaft, and then onto the lower spring seat.
9. Install the upper spring seat onto the shock. The 1-3/4" diameter counter bore in the upper spring seat goes against the top eye, and the 2-1/2" diameter ledge goes into the spring.

**NOTE:** In most cases, you will have to compress the spring slightly to slide the spring seat between the spring and top eye. Holding the shock by the lower eye in a soft-jaw-equipped vise or use of a spring compressor will make installation easier with higher rate springs.

10. Once the upper seat is in place, screw the lower seat upward until it holds the spring and upper seat in place without free play. DO NOT screw the lower seat more than one-half turn past the point at which free play is taken up and the spring cannot rattle.
11. Prepare each coil-over shock as instructed above.

# VERIFY RIDE HEIGHT

After all suspension clearances have been checked and the shocks installed onto the vehicle with the springs, you must verify that the shocks rest at ride height within their allowable range of operation.

- The suspension must carry the full weight of the complete vehicle, including interior and passenger weight, with the wheels on the ground during measurement.
- Measure the length of the shock and compare to Shock Specifications chart to ensure you are within the Ride Height range. Spring preload will need to be adjusted at the lower spring seat until both shocks measure equal to each other and are at the correct length.
- **SUSPENSION MUST BE AT FULL EXTENSION AND THE VEHICLE SAFELY SUPPORTED WHILE ADJUSTING THE LOWER SPRING SEAT.**
- With the vehicle weight carried by the suspension, it is easier to get an accurate measurement from the bottom of the upper spring seat to the top of the lower crossbar tab.
- **DO NOT THREAD THE LOWER SPRING SEAT UPWARD MORE THAN 1/2" FROM IT'S LOWEST POSITION.**
- If more than 1/2" of preload is needed to raise the vehicle into the correct ride height range, you must step up to a heavier spring rate. Failure to increase the spring rate will allow the spring to abruptly coil-bind before full shock compression, limit suspension travel, and damage the shock and related chassis and suspension components.

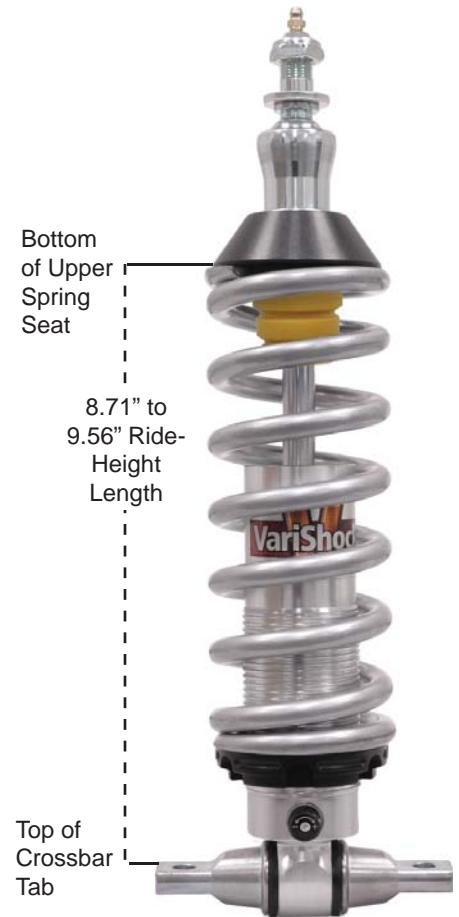

## Shock Ride-Height Specifications

Part Number	Valving	Mounting		Total Travel	Compressed Length*	Extended Length*	Ride Height*		Spring Length
		Upper	Lower				Min.	Max.	
VAS 161MS-425	Single	Spherical Stem	Crossbar	4.25"	7.01"	11.26"	8.71"	9.56"	9"

\* Shock length is measured from the top of the coil spring to the top surface of the lower crossbar tab. It is easiest to measure between these two points once the shock has been mounted to the vehicle.

## Spring Selection Guidelines

A good spring rate baseline for compact cars (i.e. Falcon, Maverick, Mustang, Chevy II with an iron small block) would be 450 lb./in.

Differences that alter desired spring rate:

- Weight Reduction -50 lbs (fiberglass hood)
- Aluminum Heads -50 lbs
- Big Block +100 lbs
- Road Race +50 lbs (better handling)
- Drag Race -50 lbs (more stored energy)

Spring rate effects ride quality, ride height and roll rate characteristics. Differences in vehicles such as aluminum engine components, fiberglass body parts and chassis stiffening should be taken into consideration. Additional springs can be purchased for tuning purposes.

## 9" VariSprings

Rate (lb/in)	Part Number
450	VAS 21-09450
500	VAS 21-09500
550	VAS 21-09550
600	VAS 21-09600
675	VAS 21-09675
750	VAS 21-09750
850	VAS 21-09850

# Determining Your Baseline Spring Rate

Determining the correct spring rate and correctly adjusting your suspension is very important to achieving the best possible and most reliable performance from your components. In fact, the vast majority of problems people experience with coil-over shocks can be attributed to using the wrong spring rate or incorrect adjustment of the shocks many settings.

## What is the Baseline Spring Rate?

“Baseline spring rate” is defined as the pound-per-inch rate (lb/in) at which the spring supports the corner weight of the vehicle with the coil-over shock at the correct installed height without the need to preload the spring. Once the baseline spring rate has been established, the vehicles performance goals and further testing will reveal the correct final spring rate for each installation. Differences such as how the spring is mounted (installation motion ratio), vehicle weight reduction, chassis stiffening, specific performance application, and driver preference and skill level all have a bearing upon the correct final spring rate.

## Where to Begin? (Initial Spring Rate)

Based on our experience with vehicles and performance applications similar to your own, Chassisworks can recommend an “initial spring rate” to install on your vehicle, from which the correct baseline spring rate can be derived. In many cases our recommended initial spring rate will be the correct baseline spring rate. However, due to the sheer number of variables, it is impossible for our technical staff to predict the precise baseline spring rate for each and every installation scenario. To assist you in obtaining the correct spring rate, a second set of springs can be purchased at a discount.

## Taking Measurements

Chassisworks has developed a simple method to determine the correct baseline spring rate. This method requires installation of our initially recommended spring, followed by a couple quick measurements and some simple calculations. Before getting started, the vehicle must be 100% complete. This includes interior, glass, fluids, weight ballasts, and sand bags or free weights to substitute as the weight of the driver. At this point, the springs should already be installed on the shocks with NO PRELOAD and ready to go onto the vehicle. *Lower spring seats should be just tight enough to remove free play from the spring.*

1. Record the initial spring rate as value “R” in the calculation table that follows. Most VariSprings will have the rate printed directly on them.
2. With the shock fully extended, measure the installed free-length of the spring. At the upper-spring-seat slot, hook the end of the tape measure against the spring and measure, with one sixteenth-of-an-inch accuracy, the distance to the ground bottom edge of the spring. Record this dimension as value “F” in the calculation table that follows.

**NOTE:** The measured length may differ slightly from the nominal spring length. In our example the 9” VariSpring actually measures 8-15/16” when correctly installed.

3. Install all shocks and springs onto the vehicle and lower it to the ground.



Hook the tape measure against the spring at the upper spring seat slot.



Measure the bottom end of the spring.



4. Verify that the springs are supporting the full weight of the vehicle. Any chassis or shock bump stops that are in contact must be temporarily removed. Make sure to replace bump stops when finished.
5. Measure the springs again at their newly collapsed installed height to within one sixteenth-of-an-inch accuracy from the same spring reference points used previously. Record this dimension as value "L" in the calculation table that follows.

### Installed Height by Performance

When a shock is at installed length (ride height) a certain amount of travel is available in either direction. Depending upon performance application, shock travel will be reserved in different percentages for bump (shock compressing) and rebound (shock extending). Use the Reserved Shock Travel Percentage Guidelines and appropriate chart to determine the amount of bump travel required to collapse the shock to the correct installed length for your performance application. Record this dimension as value "T" in our calculations.

**NOTE:** In our example calculation, a handling performance application with a 4.25"-travel coil-over shock lists a "T" value of 2.13.

## Perform the Calculations

### Calculation Table

The leftmost column in the calculation table gives you a place to record your values. Use a pencil in case you make a mistake.

Record Values	Variable	Description
___ __. ___ __	<b>F</b>	measured initial Free length of installed unloaded spring
___ __. ___ __	<b>L</b>	measured Loaded spring compressed length
F - L	Answer 1	Subtract L from F
___ __ ___ lb/in	<b>R</b>	initial spring Rate in pounds per inch
Answer 1 x R	Answer 2	Multiply Answer 1 by R
___ __. ___ __	<b>T</b>	spring Travel to achieve desired ride height (from chart on pg. 13)
Answer 2 ÷ T	<b>BASELINE SPRING RATE</b>	Divide Answer 2 by T

### Example:

Measured free length (F) 8-15/16" or 8.94

Minus measured loaded length (L) 6-1/2" or 6.50

$$8.94F - 6.50L = 2.44$$

Multiply that answer by the current spring rate 500 lb/in

$$2.44 \times 500R = 1220$$

Divide that answer by the correct (T) value in chart

$$1220 \div 2.13T = 572.77B$$

Round the final answer up or down to a suitable spring rate.

$$\frac{(F - L) R}{T} = \text{Baseline Spring Rate}$$

# Reserved Shock Travel Percentage Guidelines

## Street Baseline: 60-percent Bump, 40-percent Rebound

Street vehicles require more available compression (bump) travel for improved ride quality and unexpected road hazards. At baseline ride height, the shock and spring should collapse 40-percent from their installed heights. This results in 40-percent of travel available for extension and 60-percent for compression travel.

## Handling Baseline: 50-percent Bump, 50-percent Rebound

Handling performance applications are usually limited to smooth prepared road-course- or autocross tracks, therefore less compression travel is required. Suspension geometry or track conditions may require the travel percentages to be shifted to prevent topping- or bottoming-out the shock.

## Drag Race Baseline: 40-percent Bump, 60-percent Rebound

Drag race vehicles generally require more extension (rebound) travel to help weight transfer, and because the drag strip is very flat, less compression travel is needed. The amount of extension travel available in the shock will drastically affect how the car works. At baseline ride height, the shock and spring should collapse 60- percent from their installed heights. This results in 60-percent of travel available for extension and 40-percent of compression travel.

Optionally, it is acceptable to adjust the shock's installed height to any length between the minimum and maximum spring-length value shown in the chart. This range allows you to adjust the vehicle ride height a small amount by using the threaded lower spring seat.

## VariShock Coil-Over Shocks

Coil-Over Shock Travel	Street	Handling	Drag	Spring Free Length	Street	Handling	Drag
	60/40	50/50	40/60		Max.	Center	Min.
	<i>(T) Spring Travel Used At Ride Height</i>				<i>Installed Spring Length At Ride Height</i>		
4.25	1.70	2.13	2.55	9	7.30	6.88	6.45

# VariSpring Adjustment and Tuning Guide

Once the baseline spring rate has been determined, you are better prepared to make decisions with regards to changing spring rates for the purpose of tuning the suspension. Suspension tuning involves multiple variables such as: spring rates, anti-roll-bar rates, vehicle weight distribution, tire sizes, tire pressures, suspension geometry, and track conditions. The information contained in this tuning guide covers basic tuning procedures and has been greatly simplified to get you started in the right direction. We strongly recommend researching suspension tuning and vehicle dynamics, or consulting an experienced professional for further understanding of the pros and cons of making each adjustment.

## Tuning Categories

VariSpring's broad range of spring rates and lengths are suitable to the three categories of suspension tuning: Ride Quality, Handling Performance, and Drag Racing. All three tuning categories have the common goal of controlled weight transfer, but have greatly differing vehicle-dynamic requirements. Each will be discussed in the following text.

Before proceeding verify that all suspension components, such as control arms, balljoints, and bushings are in acceptable condition and that tire pressures are correctly set.

## Correcting Shock Installed Length

Threaded spring seats allow installation of spring rates that differ from the baseline spring rate for the purpose of performance tuning. With the spring free from the weight of the vehicle and the shock at full extension, spring seats can be threaded up or down to keep the shock at the correct collapsed install height. Raising the spring seat to compress the coil spring to any length shorter than it's free height, with the shock fully extended, is referred to as preloading the spring. During the tuning process if you elect to use a coil spring that is lighter than the calculated baseline spring rate, it may be necessary to add preload to achieve the correct balance of travel and ride height. If preload has been added make sure there is adequate spring travel remaining to prevent coil bind before the shock is fully collapsed.

## Raising or Lowering Ride Height

The spring seats are not intended to alter the vehicle's ground clearance beyond the allowed range of ride-height shock lengths. Altering ride height in this manner, risks damaging the shocks due to the lack of reserved travel in either direction. Other options for altering the vehicle's ground clearance must be employed. Then include moving the upper or lower shock mount, changing to a different length shock, or changing tire diameter.

## Adjustable Shock Mounts

Chassisworks manufactures many different styles of adjustable shock mounts to accommodate coil-over installation on both aftermarket and OEM chassis. If an adjustable shock mount cannot be used, then a longer or shorter coil-over will be required. Keep in mind that a shorter coil-over does lower the vehicle, but with a reduced amount of travel and a stiffer spring, making spring selection much more exacting and the possibility of a good ride more difficult.

## Appropriate Shock Lengths

As a general rule, never use anything shorter than a 5"-travel rear shock. You also want to have at least 5 inches of front end travel. You can accomplish this with a 3.50" or 4.25" travel shock depending on the motion ratio of the front lower a-arm. As a practical matter a 4.25" travel front shock will give between 5.75" to 7.0" of front travel on most A-arms and has a lot broader selection of spring rates. As it has more travel, your installed length range varies up to .80" which will equate to a 1.25" range at the wheel to help you adjust your vehicle ride height without modifying the shock mount. That is why most Chassisworks designs use the 4.25" shock. It is clearly a better choice for performance cars.

## Spring Tuning for Ride Quality

Tuning for ride quality generally involves spring rates that are at or slightly below the baseline spring rate, matched with softer shock settings to achieve a smooth and comfortable ride. Use of adjustable shocks allows softer settings for regular street use that can easily be changed to a stiffer setting for mild performance use. When properly adjusted for street use the vehicle should feel settled without continued bouncing (too soft), excessive harshness (too stiff), or fore/aft pitching. The vehicle's cornering ability can be improved with the addition of a moderately-sized front anti-roll bar. A moderate-size anti-roll bar will reduce body roll during cornering without increasing ride harshness over uneven surfaces. We feel that this general approach yields a comfortable driving vehicle that can be easily moved toward more performance oriented driving when used with adjustable shocks. Testing and adjustment is required to attain desirable results.

<b>Shocks Topping- or Bottoming-Out</b>	Increase Stiffness	If the shocks are within their allowed installed-height range and repeatedly exceed the travel limits of the shock, increase spring rates or shock stiffness to reduce the amount of suspension travel.
<b>Excessive Chassis Movement</b>	Increase Stiffness	If vehicle exhibits rapid weight shifts or continues to oscillate more than one suspension cycle before settling, increase spring or shock stiffness, then test again. As stiffness is increased, road noise and vibration will also increase. Note: Stiffening the shock does not reduce the amount of lean or dive in a sustained turn or braking maneuver, but does slow the rate of weight transfer to minimize unexpected changes in the cars handling.
<b>Harshness and Vibration</b>	Decrease Stiffness	If excessive road noise, vibration, or harshness is experienced decrease spring or shock stiffness, then test again.
<b>Fore/Aft Pitching (constant speed 50-70 mph)</b>	Alter Front-to-Rear Stiffness Difference	If vehicle exhibits fore/aft pitching at highway speeds, the rear springs or shocks should be stiffened or conversely the front springs or shocks softened. Ideally the rear suspension should oscillate at a slightly quicker rate than the front to minimize pitching.

## Spring Tuning for Handling Performance

### Corner Weighting for Handling Performance

Threaded spring seats also enable available traction to be maximized by corner weighting the vehicle. In corner weighting, the spring seats are threaded up or down to change the height of the spring, thereby increasing or decreasing the percentage of total vehicle weight carried by that spring. Ideally, the total weight that each diagonal pair of wheels shares should be equal to the opposite diagonal pair. The diagonal balance is ideal for vehicles requiring equal cornering performance in both left- and right-hand turns. Offsetting the balance can be used as an additional tuning aid if desired.

Digital scale sets are available specifically for corner balancing and provide the most accurate information. Before corner balancing, all tires must be at their correct pressure level and the vehicle must be 100% complete. This includes interior, glass, fluids, weight ballasts, and sand bags or free weights to substitute as the weight of the driver.

#### Example 1

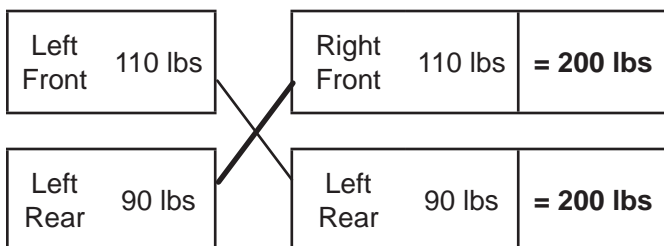

#### Example 2

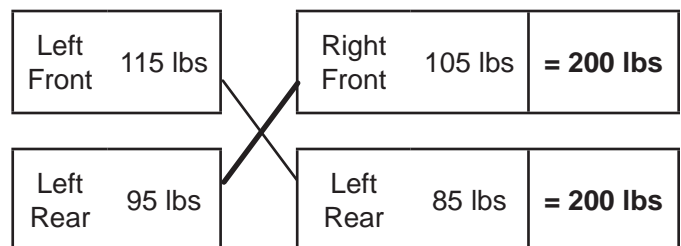

### Handling Performance Spring Tuning Strategy

Our preferred setup strategy for handling performance involves a modest spring rate, at or above the calculated baseline spring rate, adjustable shocks, and heavier-rate anti-roll bars to help control chassis movements. Generally, as the driver's and vehicle's ability to generate cornering and braking forces increases, spring rates should be increased to minimize the body roll and brake dive. Stiffer tuned suspension increases vibration transferred to the vehicle and passengers, but is usually tolerated for performance gains. There are alternate tuning approaches, but we feel that this strategy allows rapid adjustments without the requirement of multiple spring rate changes to find the correct combination of components.

As a vehicle approaches its cornering traction limit the handling characteristics of understeer and oversteer will become more apparent to the driver. Cornering balance is a result of the relationship between a multitude of factors including weight distribution, tire sizes and pressures, specific suspension geometries, spring rates, anti-roll-bar rates, and shock bump and rebound stiffness. Chassisworks' tuning strategy is to use front and rear anti-roll-bar adjustments and shock stiffness adjustments to bring the vehicle into balance. As a very basic rule of thumb; the

softer end of the vehicle will have more grip, and the stiffer end of the vehicle will have less grip. So, if the vehicle has understeer, soften the front suspension or stiffen the rear. Or, if the vehicle exhibits oversteer, soften the rear suspension or stiffen the front. For our purposes, softening or stiffening the suspension will consist of adjustments or changes to shock valving and/or anti-roll bar spring rates.

When properly adjusted the vehicle should feel responsive, exhibit balanced cornering grip, and maintain traction over irregular surface conditions. As previously stated, there are a multitude of additional adjustments that can be made to adjust cornering balance. A very basic chart is provided but the pros and cons of making each adjustment is beyond the scope of this document. If you intend to operate your vehicle at or near its performance limits, it is extremely important that extensive testing and adjustment be conducted in a safe and controlled environment, such as a dedicated motorsports facility.

<b>Excessive Chassis Movement</b>	Increase Stiffness	If vehicle exhibits rapid weight shifts, increase spring or shock stiffness, then test again. Note: Stiffening the shock does not reduce the amount of lean or dive in a sustained turn or braking maneuver, but does slow the rate of weight transfer to minimize unexpected changes in the cars handling.
<b>Reduced Traction or Skipping</b>	Decrease Stiffness	If a reduction in traction during acceleration, braking, or cornering is experienced decrease spring or shock stiffness, then test again. This will be most noticeable on rough track surfaces.
<b>Shocks Bottoming Out</b> (body roll, brake dive or squatting)	Increase Stiffness	If chassis movement during cornering or braking allows shocks to bottom out, increase spring or shock stiffness, then test again. The urethane bump stop can be used to gauge shock bump travel by sliding it down the piston rod, against the shock body, then checking its position after testing. If increasing bump stiffness cannot extend weight transfer duration long enough a higher rate spring should be installed.
<b>Understeer Condition</b> (Neutral throttle) Car turns less than expected; commonly referred to as push, plow, or tight.	Change Stiffness Bias Toward Rear	If vehicle exhibits understeer when cornering at neutral throttle, rear springs, shocks, or anti-roll bar should be stiffened. Or conversely, front springs, shocks, or anti-roll bar, softened. A slight amount of understeer is considered safe and reduces the chances of spinning.
<b>Oversteer Condition</b> (Neutral throttle) Car turns more than expected; commonly referred to as tail-happy or loose.	Change Stiffness Bias Toward Front	If vehicle exhibits oversteer when cornering at neutral throttle, front springs, shocks, or anti-roll bar should be stiffened. Or conversely, rear springs, shocks, or anti-roll bar, softened. Oversteer increases the vehicles tendency to spin when cornering and requires driver experience and skill to manage safely. This condition should be avoided by novice drivers.

## Additional Tuning Adjustments

The chart to the right provides a very basic view of how a given adjustment will affect the level of traction at the end of the vehicle on which the adjustment was made. We strongly recommend researching suspension tuning and vehicle dynamics, or consulting an experienced professional for further understanding of the pros and cons of making each adjustment.

Adjustment	More Grip	Less Grip
Spring Rate	Softer	Stiffer
Shock Valving	Softer	Stiffer
Anti-Roll Bars	Softer	Stiffer
Weight Distribution	Lighter	Heavier
Tire Size	Wider	Narrower
Tire Pressure	Lower	Higher
Roll Centers	Lower	Higher
Aerodynamic Downforce	More	Less

**NOTE:** For shock absorber tuning instructions see tuning guide shipped with shocks.

# Drag Race Spring Tuning

Required settings for drag racing applications vary greatly depending upon, vehicle weight, weight distribution, suspension geometry and travel, horsepower, and available traction. A properly tuned drag race suspension enables the vehicle to launch straight while transferring weight to the rear tires in an efficient, controlled manner. Extensive testing and adjustment is critically important when operating your vehicle at or near its performance limits. Testing must be done in a safe and controlled environment, such as a dedicated motorsports facility. It is generally better to tune suspension according to improvements in ET's (Elapsed Times) rather than for specific occurrences such as the amount of wheel stand. Due to differences in weight distribution, wheel base, tire size, and horsepower, not all vehicles leave the starting line in the same manner once their suspension has been optimized. Watch your ET's and if your times start to get slower return to the prior adjustment. Once you have completed the following procedures, only fine adjustments may be needed to tune for specific track conditions.

## What Happens During Launch?

As a drag vehicle front suspension separates (the front of the car comes up) more weight is transferred to the rear tires to aid traction. How fast the front end rises is mostly controlled by the spring rate and front shock force. As the rebound valving of the shocks is softened it will be easier for the front end to lift. Not so obvious is if the car had a softer front spring, the front suspension will lift easier also. The explanation is quite simple. A heavier rate front spring will take more force to lift the front end a fixed vertical distance, than a lighter spring. If you have 500-lb/in front springs and the acceleration force transfers 1000 pounds of front end weight to the rear; 500 from each front spring, the front end lifts one inch. With 250-lb/in front springs, the same 1000 pound weight transfer will lift the front end a total of two inches. The lighter 250-lb/in rate benefits a drag car in two ways. The front end will move faster and farther because less force is required to initially extend the spring. And, it will rise higher, transferring more weight as the center of gravity rises, further assisting traction. However, too much weight transfer can hurt your ET by causing excessive wheel stands and lost forward motion.

## Tuning Front Suspension with Spring Rate

A drag race car should run the lightest front spring rate possible, without letting the shocks bottom out when making a pass. As a general guideline, lighter springs allow the car to easily transfer weight, and settle faster down track. Changing spring rate affects ride height and the rate at which weight is transferred to the rear tires. A softer rate makes the front easier to rise during acceleration. A stiffer rate makes the front harder to rise during acceleration. If you are having trouble getting the front end to rise, you can soften shock rebound valving or change to a softer spring.

When using lighter rate springs, preload must be added by screwing the lower spring seat upward. Compressing the spring to achieve proper ride height will store energy in it. This is the very simple theory behind stored energy front drag-race springs. If you preload a spring, it is imperative that you verify that the spring has enough travel to not coil bind before the shock bottoms out. VariSprings feature a very high strength steel that allows them to be wound more coarse than traditional springs, which makes VariSprings travel farther before coil bind.

In general terms, the worse a car hooks, the more shock extension travel it will need. If you need more extension travel, preload can be removed to lower ride height. Using this method will cause the car to have less ground clearance and reduce the amount of compression travel. If you are going to operate the shock at a ride height shorter than recommended, the upper chassis mounts must be relocated to correct any major vehicle ride height issues. It may take some work with spring rates and upper mount relocation to get the correct combination of vehicle ride height and front suspension travel for your application.

## Prior to Testing

Make certain that wheelie bars are raised as high as possible while maintaining control and eliminating their influence as much as possible on suspension settings.

## Initial Testing

First verify that the vehicle tracks straight before aggressively launching from the line. Begin with light acceleration and low speeds. If the vehicle tracks and drives acceptably at this level, make incremental increases in acceleration and top speed until the vehicle is safe at higher speed. Vehicles not tracking straight at speed should verify all chassis settings including but not limited to alignment, bump steer, tire pressures, etc. Once the vehicle drives in a safe manner at speed, move on to test launching.

Test launches should consist of only the initial launch with no subsequent gear changes. Begin with low rpm launches and gradually increase rpm and severity if the car launches acceptably. At this time we are only determining that the car launches in a controlled manner to avoid damaging components or the vehicle. The vehicle should leave in a straight line without extreme wheel standing or harsh bounces. Sudden, uncontrollable front end lift should be corrected by making suspension instant center adjustments, if possible. More gradual front end lift can be corrected by adjusting the

shock valving, if possible. If the car gradually wheel stands or bounces violently, adjust front suspension first, then rear. If there is rear tire shake, wheel hop or excessive body separation, adjust rear suspension first, then front.

After the car has been adjusted to launch straight, test launch and include the first gear change. Make any required adjustments and add the next gear change. Repeat until the car can be launched straight and driven at speed safely. The car is now ready for fine tuning to optimum results.

## Front Shock Adjustment

Pay close attention to what is happening to the front end during launch. Your goal is to eliminate all jerking or bouncing movements during launch and gear shifts. Ideally the front end should rise in a controlled manner, just enough to keep the rear tires loaded, then continue the pass with smooth transitions at all times. Front end rise without any appreciable traction gain is wasted energy that should be used to propel the vehicle forward instead of up. While testing, document your ET's along with any changes made. If ET does not improve, return to previous settings.

## Front Rebound (Extension) Adjustment Overview

Too light of a spring rate or shock rebound (extension) setting allows excessive front end chassis separation and may result in the front wheels jerking violently off the ground during launch. Also, during gear change, too light a spring rate or shock setting allows the car to bounce off its front rebound travel limiter and then bottom out in an oscillating manner. Too firm a spring rate or shock setting will prevent the front end from rising sufficiently, limiting the amount of weight transferred to the rear tires. Spring rates should only be changed if the shock valving range is not great enough to correct the issue. While testing, document your ET's along with any changes made. If ET does not improve, return to previous settings.

<b>Front Wheels Lose Contact with Ground</b>	Increase Rebound Stiffness	Violent chassis separation and may result in jerking the front wheels off the ground. Increase spring or shock stiffness, then test again.
<b>Rear Tires Hook Then Lose Traction</b>	Increase Rebound Stiffness	If weight transfer occurs too quickly the rear tires may hook then lose traction as the front end begins to travel downward. Slowing the rate at which the front end rises prevents the shocks from topping out too quickly and increases the duration of time that the rear tires benefit from the weight transfer. Increase spring or shock stiffness, then test again.
<b>No Front End Rise</b>	Decrease Rebound Stiffness	Too firm of a shock setting limits the amount of weight transferred to the rear tires, resulting in poor traction. Decrease spring or shock, then test again.

## Front Bump (Compression) Adjustment Overview

After the launch or during a gear change, a firm spring or shock setting will cause the chassis to bounce off the front tire as the chassis settles down. Too light of a spring or bump setting allows the shock to bottom out and bounce off the stop travel bumper. Spring rates should only be changed if the shock valving range is not great enough to correct the issue. While testing, document your ET's along with any changes made. If ET does not improve, return to previous settings.

<b>Front "Bottoms Out" After Launch</b>	Increase Stiffness	If front suspension settles too fast after launch or gear change it may cause the front suspension to bottom out at the end of its downward travel. If the suspension bottoms out hard enough, rear traction may be lost. Increase spring or shock stiffness, then test again. If increasing shock stiffness cannot extend weight transfer duration long enough, a higher rate spring should be installed.
<b>Hard Front End Bounce</b> (After Launch or Gear Change)	Decrease Bump Stiffness	If the tires cause the front end to bounce upon landing, the shocks are too stiff. The front end should settle in a single, smooth motion. Decrease spring or shock stiffness, then test again. This can be a very subtle problem. Watch the front tire sidewall as it contacts the ground.

# VariShock Adjustment and Tuning Guide

## QuickSet 1

This guide covers adjustment features and tuning procedures for VariShock QuickSet 1, single-adjustable, shock absorbers. The information contained has been greatly simplified and is only intended to get you started in the right direction. Suspension tuning involves multiple variables such as: spring rates, antiroll bar rates, vehicle weight distribution, tire sizes, tire pressures, suspension geometry, and track conditions. We highly recommend thoroughly researching suspension tuning and vehicle dynamics, or consulting an experienced professional.

### Travel Limiters

Shocks are not to be used as travel limiters. An extension travel limiter, such as a strap or cable, should be used to prevent topping out and damaging the shocks. The installed compression bumper protects the shock if bottomed out during normal use. If the bumper shows signs of wear or damage it must be replaced immediately. Never operate a vehicle with a missing or damaged bumper. Vehicles that consistently bottom out shocks or land harshly from wheel stands should use a higher rate spring along with some form of suspension stop to limit compression travel without directly impacting the shock body. Any shock will be damaged if the car is dropped from a wheel stand.

### Ride Height

When a shock is at ride height a certain amount of travel is available in either direction. Depending upon performance application, shock travel will be reserved in different percentages for compression or extension.

#### **Street Baseline: 60-percent Bump, 40-percent Rebound**

Street vehicles require more available compression (bump) travel for improved ride quality and unexpected road hazards. At baseline ride height, the shock and spring should collapse 40-percent from their installed heights. This results in 40-percent of travel available for extension and 60-percent for compression travel.

#### **Handling Baseline: 50-percent Bump, 50-percent Rebound**

Handling performance applications are usually limited to smooth prepared road-course- or autocross-tracks, therefore less compression travel is required. Suspension geometry or track conditions may require the travel percentages to be shifted to prevent topping- or bottoming-out the shock.

#### **Drag Race Baseline: 40-percent Bump, 60-percent Rebound**

Drag race vehicles generally require more extension (rebound) travel to help weight transfer, and because the drag strip is very flat, less compression travel is needed. The amount of extension travel available in the shock will drastically affect how the car works. At baseline ride height, the shock and spring should collapse 60-percent from their installed heights. This results in 60-percent of travel available for extension and 40-percent of compression travel.

### Baseline Spring Rate Selection

Spring rate affects ride quality, ride height, stored energy, weight transfer and how effectively the front suspension handles downward movement after drag race launches. Differences in vehicles such as specific performance application, weight reduction and chassis stiffening should be taken into consideration. Additional springs can be purchased for tuning purposes. The recommended spring rates are based on the combination of weight of the car and baseline ride height.

### Spring Preload

The threaded lower spring seat is used to adjust spring preload. Compressing the coil spring to any length shorter than it's free height, with the shock fully extended, is considered preloading the spring. If you adjust the spring seat to change the vehicle's ground clearance, be aware that you will be adding or subtracting travel in the shock. Usually when lighter-than-baseline spring rates are used it is necessary to add preload to achieve the correct balance of travel and ride height. If preload has been added make sure there is adequate spring travel remaining to prevent coil bind before the shock is fully collapsed.

## Tuning Front Suspension with Spring Rate (Drag Race)

A drag race car should run the lightest front spring rate possible, without letting the shocks bottom out when making a pass. As a general guideline, lighter springs allow the car to easily transfer weight, and settle faster down track. Changing spring rate affects ride height and the rate at which weight is transferred to the rear tires. A softer rate makes the front easier to raise during acceleration. A stiffer rate makes the front harder to raise during acceleration. If you are having trouble getting the front end to rise, you can soften shock valving or change to a softer spring. When using lighter rate springs preload must be added by screwing the lower spring seat upward, compressing the spring to achieve proper ride height. In general terms, the worse a car hooks the more shock extension travel it will need. If you need more extension travel, preload can be removed to lower ride height. Using this method will cause the car to have less ground clearance and reduce the amount of compression travel. If you are going to operate the shock at a ride height shorter than recommended, the upper chassis mounts must be relocated to correct any major vehicle ride height issues. It may take some work with spring rates and upper mount relocation to get the correct combination of vehicle ride height and front suspension travel for your application.

## Adjustment Features

The QuickSet 1 valve system features a single adjustment knob that controls overall damping stiffness of the shock. Knobs are clearly etched indicating the correct direction of rotation to decrease (-), or increase (+) damping stiffness. There are a total of 16 specific adjustment positions.

Position 1, the softest setting, is found by turning the knob in the counter-clockwise direction until the positive stop is located. Rotating the knob in the clockwise direction increases damping stiffness. Each of the 16 settings is indicated by a detent that can be felt when turning the knob, and an audible click as the knob gently locks into position. Only very light force is necessary to rotate the knob past each detent. If access to the adjustment knobs is limited, a 5/64 or 7/64 (depending upon model) ball-drive Allen wrench can be used to adjust the knob. Do not force the knob beyond its intended stop, doing so will damage the valve mechanism.

**Note:** VariShocks have a substantial range of adjustment with very little bypass or internal bleed. Due to our minimal-bleed design, shocks will feel extremely stiff at some settings when operated by hand, whereas other shocks with excessive bleed will move more freely. Manual comparison should not be performed. A person cannot manually operate the shock at a rate anywhere near real life conditions and any results found in this manner will be meaningless. Prior to shipping, every VariShock is dynamometer (dyno) tested and calibrated throughout an accurate range of shaft speeds and cylinder pressures found in real-world operation.

## The Truth About 16- vs. 24-Clicks

Don't be fooled by shocks offering more adjustment clicks. They are actually 1/2-click adjustments. The manufacturer merely added more detents to the mechanism without increasing the range of adjustment. This practice gives more clicks, but the adjustment is so slight that your vehicle will not respond to the change. A 16-position VariShock actually has a broader range of adjustable force with the added benefit of a more manageable number of adjustments to try.

## Tuning Procedures - QuickSet 1

VariShock shock absorber's broad range of adjustment is suitable to the three categories of suspension tuning: ride quality, handling performance, and drag racing. All three tuning categories have the common goal of controlled weight transfer, but have greatly differing vehicle-dynamic requirements. Each will be discussed in the following text. Before proceeding verify that all suspension components, such as control arms, balljoints, and bushings are in acceptable condition and that tire pressures are correctly set.

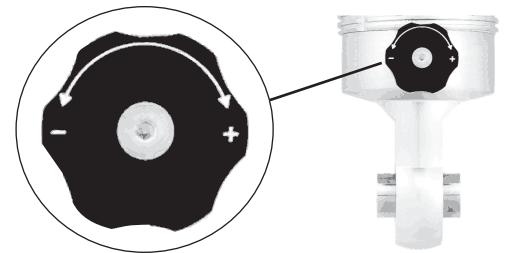

Symbol	Direction	Effect
+	Clockwise	Increase Stiffness
-	Counter-Clockwise	Decrease Stiffness
Note:	Adjusts overall damping stiffness for Bump and Rebound simultaneously.	

# Shock Tuning for Ride Quality - QuickSet 1

Tuning for ride quality generally involves lighter spring rates matched with softer shock settings to achieve a smooth and comfortable ride. Testing and adjustment is required to attain desirable results. When properly adjusted the vehicle should feel settled without continued bouncing (too soft), excessive harshness (too stiff), or fore/aft pitching.

## Prior to Testing

Begin with the shocks adjusted to the number 3 position. The first two settings are generally too soft for street use and are normally used in drag racing applications.

## Find Harshness Threshold

Noticable ride harshness is generally rapid upward movement of the suspension as the tire travels over rough or bumpy surfaces. Increase shock stiffness by one, then test again. Continue increasing stiffness and testing until the vehicle begins to feel harsh over bumps. From this setting, decrease shock stiffness by two. The harshness threshold setting may differ from front to rear.

<b>Excessive Chassis Movement</b>	Increase Stiffness	If vehicle exhibits rapid weight shifts or continues to oscillate more than one suspension cycle before settling, increase shock stiffness by one, then test again. As stiffness is increased, road noise and vibration will also increase. Note: Stiffening the shock does not reduce the amount of lean or dive in a sustained turn or braking maneuver, but does slow the rate of weight transfer to minimize unexpected changes in the cars handling.
<b>Harshness and Vibration</b>	Decrease Stiffness	If excessive road noise, vibration, or harshness is experienced decrease shock stiffness by one, then test again.
<b>Fore/Aft Pitching (constant speed 50-70 mph)</b>	Alter Front-to-Rear Stiffness Difference	If vehicle exhibits fore/aft pitching at highway speeds, the rear shocks should be stiffened or conversely the front shocks softened. Ideally the rear suspension should oscillate at a slightly quicker rate than the front to minimize pitching.

# Shock Tuning for Handling Performance - QuickSet 1

Heavier spring rates matched with stiffer shock settings generally contribute to improved handling performance by reducing chassis movement. Stiffer tuned suspension increases vibration transferred to the vehicle and passengers, but is usually tolerated for performance gains. When properly adjusted the vehicle should feel responsive, exhibit balanced cornering grip, and maintain traction over irregular surface conditions. Extensive testing and adjustment is critically important when operating your vehicle at or near its performance limits. Testing must be done in a safe and controlled environment, such as a dedicated motorsports facility.

## Prior to Testing

Begin with the shocks adjusted to the number 5 position. The first four settings are generally too soft for performance applications and are normally used in drag racing or street applications.

## Find Harshness Threshold

Harshness is vibration transferred to the chassis by rapid upward movement of the suspension as the tire travels over rough or bumpy surfaces. Increase shock stiffness by one, then test again. Continue increasing stiffness and testing until the vehicle begins to feel harsh over bumps, or a reduction of traction, cornering, braking or acceleration ability is experienced. From this setting, decrease shock stiffness by one. The harshness threshold setting may differ from front to rear.

<b>Excessive Chassis Movement</b>	Increase Stiffness	If vehicle exhibits rapid weight shifts, increase shock stiffness by one, then test again. Note: Stiffening the shock does not reduce the amount of lean or dive in a sustained turn or braking maneuver, but does slow the rate of weight transfer to minimize unexpected changes in the cars handling.
<b>Reduced Traction or Skipping</b>	Decrease Stiffness	If a reduction in traction during acceleration, braking, or cornering is experienced decrease shock stiffness by one, then test again. This will be most noticeable on rough track surfaces.
<b>Shocks Bottoming Out</b> (body roll, brake dive or squatting)	Increase Stiffness	If chassis movement during cornering or braking allows shocks to bottom out, increase shock stiffness by one, then test again. The urethane bump stop can be used to gauge shock bump travel by sliding it down the piston rod, against the shock body, then checking its position after testing. If increasing bump stiffness cannot extend weight transfer duration long enough a higher rate spring should be installed.
<b>Understeer Condition</b> (Neutral throttle) Car turns less than expected; commonly referred to as push, plow, or tight.	Change Stiffness Bias Toward Rear	If vehicle exhibits understeer when cornering at neutral throttle, rear shock should be stiffened or conversely, front shock softened. A slight amount of understeer is considered safe and reduces the chances of spinning.
<b>Oversteer Condition</b> (Neutral throttle) Car turns more than expected; commonly referred to as tail-happy or loose.	Change Stiffness Bias Toward Front	If vehicle exhibits oversteer when cornering at neutral throttle, front shock should be stiffened or conversely, rear shock softened. Oversteer increases the vehicles tendency to spin when cornering and requires driver experience and skill to manage safely. This condition should be avoided by novice drivers.

## Shock Tuning for Drag Racing - QuickSet 1

Required settings for drag racing applications vary greatly depending upon, vehicle weight, weight distribution, suspension geometry and travel, horsepower, and available traction. A properly tuned drag race suspension enables the vehicle to launch straight while transferring weight to the rear tires in an efficient, controlled manner. Extensive testing and adjustment is critically important when operating your vehicle at or near its performance limits. Testing must be done in a safe and controlled environment, such as a dedicated motorsports facility. It is generally better to tune shocks according to improvements in ET's (Elapsed Times) rather than for specific occurrences such as the amount of wheel stand. Due to differences in weight distribution, wheel base, tire size, and horsepower, not all vehicles leave the starting line in the same manner once their suspension has been optimized. Watch your ET's and if your times start to get slower return to the prior adjustment. Once you have completed the following procedures, only fine adjustments may be needed to tune for specific track conditions.

### Prior to Testing

Make certain that wheelie bars are raised as high as possible while maintaining control and eliminating their influence as much as possible on damper settings. Begin with shocks adjusted to the number 3 position.

### Initial Testing

First verify that the vehicle tracks straight before aggressively launching from the line. Begin with light acceleration and low speeds. If the vehicle tracks and drives acceptably at this level, make incremental increases in acceleration and top speed until the vehicle is safe at higher speed. Vehicles not tracking straight at speed should verify all chassis settings including but not limited to alignment, bump steer, tire pressures, etc. Once the vehicle drives in a safe manner at speed, move on to test launching.

Test launches should consist of only the initial launch with no subsequent gear changes. Begin with low rpm launches and gradually increase rpm and severity if the car launches acceptably. At this time we are only determining that the car launches in a controlled manner to avoid damaging components or the vehicle. The vehicle should leave in a straight line without extreme wheel standing or harsh bounces. Sudden, uncontrollable front end lift should be

corrected by making suspension instant center adjustments, if possible. More gradual front end lift can be corrected by adjusting the shock valving. If the car gradually wheel stands or bounces violently, adjust front suspension first, then rear. If there is rear tire shake, wheel hop or excessive body separation, adjust rear suspension first, then front. If your car is launching severely to the right or left, first check that the rear end is centered and there is no preload adjusted into the rear suspension. If the car still launches severely to the right or left, you will have to add preload to the rear suspension. If everything checks out okay and the car only minimally drives to the right or left, you can stagger the rear shock valving to correct this.

When a vehicle launches slightly toward the right, rear shock stiffness is increase on the driver side and shock stiffness is decreased on the passenger side. A vehicle launching slightly toward the left would make the opposite adjustments. It is not recommended to have more than two clicks difference side to side. Rear shock adjustments are only applicable to correcting the launch and will have little to no affect on down track performance.

After the car has been adjusted to launch straight, test launch and include the first gear change. Make any required adjustments and add the next gear change. Repeat until the car can be launched straight and driven at speed safely. The car is now ready for fine tuning to optimum results.

## Front Shock Adjustment

Pay close attention to what is happening to the front end during launch. Your goal is to eliminate all jerking or bouncing movements during launch and gear shifts. Ideally the front end should rise in a controlled manner, just enough to keep the rear tires loaded, then continue the pass with smooth transitions at all times. Front end rise without any appreciable traction gain is wasted energy that should be used to propel the vehicle forward instead of up. While testing, document your ET's along with any changes made. If ET does not improve, return to previous settings.

## Single-Adjustable Shock Limitations

The use of a single-adjustable shock will have limited tuning capability. When adjusting the shock to improve rebound (extension) travel issues you are also adjusting bump (compression) stiffness. This may worsen or create bump travel issues. As an example using a soft shock setting that improves front end rise and weight transfer, may be too soft to prevent the shocks from bottoming out as the front end lands. You must decide which correction will best improve component reliability, driveability, and ET. This performance trade-off relationship is unavoidable with a single-adjustable shock. To truly maximize tuning capability a double-adjustable shock should be used.

## Front Rebound (Extension) Adjustment Overview

Too light of a shock setting allows excessive front end chassis separation and may result in the front wheels jerking violently off the ground during launch. Also, during gear change, too light a setting allows the car to bounce off its front rebound travel limiter and then bottom out in an oscillating manner. Too firm a setting will prevent the front end from rising sufficiently, limiting the amount of weight transferred to the rear tires. Adjust shock stiffness in one click increments to control the rate at which the front end rises at launch and during gear changes. While testing, document your ET's along with any changes made. If ET does not improve, return to previous settings.

<b>Front Wheels Lose Contact with Ground</b>	Increase Stiffness	Violent chassis separation and may result in jerking the front wheels off the ground. Increase shock stiffness by one, then test again.
<b>Rear Tires Hook Then Lose Traction</b>	Increase Stiffness	If weight transfer occurs too quickly the rear tires may hook then lose traction as the front end begins to travel downward. Slowing the rate at which the front end rises prevents the shocks from topping out too quickly and increases the duration of time that the rear tires benefit from the weight transfer. Increase shock stiffness by one, then test again. If ET does not improve, return to previous setting.
<b>No Front End Rise</b>	Decrease Stiffness	Too firm of a shock setting limits the amount of weight transferred to the rear tires, resulting in poor traction. Decrease shock stiffness by one, then test again. If ET does not improve, return to previous setting.

## Front Bump (Compression) Adjustment Overview

After the launch or during a gear change, too firm of a setting will cause the chassis to bounce off the front tire as the chassis settles down. Too light of a setting allows the shock to bottom out and bounce off the stop travel bumper. Adjust shock stiffness in one click increments to control the amount and rate at which the front end settles during gear change. While testing, document your ET's along with any changes made. If ET does not improve, return to previous settings.

<b>Front “Bottoms Out” After Launch</b>	Increase Stiffness	If front suspension settles too fast after launch or gear change it may cause the front suspension to bottom out at the end of its downward travel. If the suspension bottoms out hard enough, rear traction may be lost. Increase shock stiffness by one, then test again. If increasing shock stiffness cannot extend weight transfer duration long enough, a higher rate spring should be installed.
<b>Hard Front End Bounce</b> (After Launch or Gear Change)	Decrease Stiffness	If the tires cause the front end to bounce upon landing, the shocks are too stiff. The front end should settle in a single, smooth motion. Decrease shock stiffness by one, then test again. This can be a very subtle problem. Watch the front tire sidewall as it contacts the ground.

### Rear Shock Adjustment (Single Adjustable)

Maintain traction by controlling the rate at which torque and weight is transferred to the rear tires. Ideally the rear suspension should be as firm as possible before a loss of traction occurs. Changes to the vehicle such as ride height, tire size, weight distribution, or suspension link adjustments will alter the instant center location in relation to the vehicle’s center of gravity. Any shift of either the instant center or center of gravity will usually require a shock setting adjustment to optimize traction. While testing, document your ET’s along with any changes made. If ET does not improve, return to previous settings.

<b>Rear End Squats</b>	Increase Stiffness	Some vehicles will squat during launches instead of pushing the vehicle forward. To assist in planting the tires, increase shock stiffness by one, then test again. If ET does not improve, return to previous setting.
<b>Vehicle Separates from Rear End</b>	Increase Stiffness	Some suspension geometries plant the tires so forcefully that the rear end of the vehicle rises away from the housing too rapidly. The vehicle may hook initially, then spin the tires once the shocks are topped out. Slowing the rate at which the rear end rises increases the duration of time that the rear tires benefit from the improved traction. Increase shock stiffness by one, then test again. If ET does not improve, return to previous setting.
<b>Loss of Traction with Minimal Chassis Movement</b>	Decrease Stiffness	A suspension system that is too stiff can hit the tires too hard, causing a loss of traction. Softening the suspension slows the transfer of weight and reduces the initial tire shock. Decrease shock stiffness by one, then test again. If ET does not improve, return to previous setting.

### Completion of Testing

When all adjustments have been completed, reset your wheelie bars as low as possible without affecting your ET.

**Notes:**

**Notes:**

**WARRANTY NOTICE:**

There are NO WARRANTIES, either expressed or implied. Neither the seller nor manufacturer will be liable for any loss, damage or injury, direct or indirect, arising from the use or inability to determine the appropriate use of any products. Before any attempt at installation, all drawings and/or instruction sheets should be completely reviewed to determine the suitability of the product for its intended use. In this connection, the user assumes all responsibility and risk. We reserve the right to change specification without notice. Further, Chris Alston's Chassisworks, Inc., makes **NO GUARANTEE** in reference to any specific class legality of any component. **ALL PRODUCTS ARE INTENDED FOR RACING AND OFF-ROAD USE AND MAY NOT BE LEGALLY USED ON THE HIGHWAY.** The products offered for sale are true race-car components and, in all cases, require some fabrication skill. **NO PRODUCT OR SERVICE IS DESIGNED OR INTENDED TO PREVENT INJURY OR DEATH.**

Chris Alston's Chassisworks  
8661 Younger Creek Drive  
Sacramento, CA 95828  
Phone: 916-388-0288  
Technical Support: tech@cachassisworks.com

