

READ ALL INSTRUCTIONS COMPLETELY AND THOROUGHLY UNDERSTAND THEM BEFORE DOING ANYTHING.
CALL TOTAL CONTROL PRODUCTS TECH SUPPORT (916) 388-0288 IF YOU NEED ASSISTANCE.

INSTALLATION GUIDE

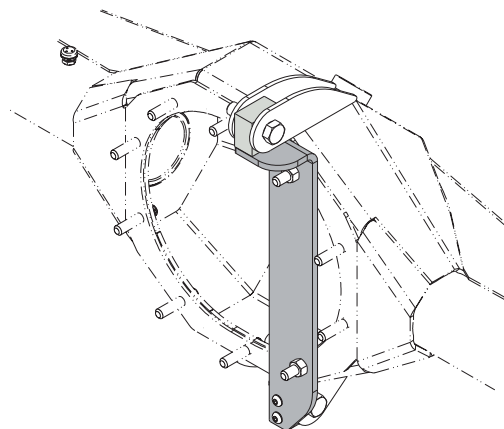

TCP TABKT-1 Torque Arm Bracket Installation Tool for Ford Rearend Housings (8", 9", FAB9)



Description: Fixture for welding torque arm upper and lower brackets onto FAB9, Ford 9", or Ford 8" rearend housings. Direct bolt-on positioning for FAB9 and Ford 9" housings. Clamps required for use with Ford 8".

ITEM	QTY	PART NO.	DESCRIPTION
1	2	7917-027	TORQUE ARM TAB, UPPER REAREND HOUSING, Ø1/2 HOLE, TCP
2	2	7917-028	TORQUE ARM TAB, LOWER REAREND HOUSING, Ø1/2 HOLE, TCP
3	1	7917-038	LOCATOR BLOCK SUPPORT TORQUE ARM TAB WELD FIXTURE
4	2	7917-037	LOCATOR BLOCK, HOUSING TABS, WELD FIXTURE, TCP TORQUE ARM
5	4	3104-025C0.63C	BUTTON HEAD SOCKET CAP SCREW 1/4-20 x 5/8
6	2	3102	BOLT, 1/2-20 x 2 HEX CAP SCREW, GRADE 8, PLATED
7	2	3206	1/2-20 HEX JAM NUT PLATED
8	2	3259	HEX NUT, 3/8-24, CLEAR ZINC PLATED

NOTE: DRAWING AND NOTES APPLY TO FAB9 AND FORD 9" ONLY. FORD 8" FIXTURE POSITION SHOWN IN DRAWING ON BACK PAGE.

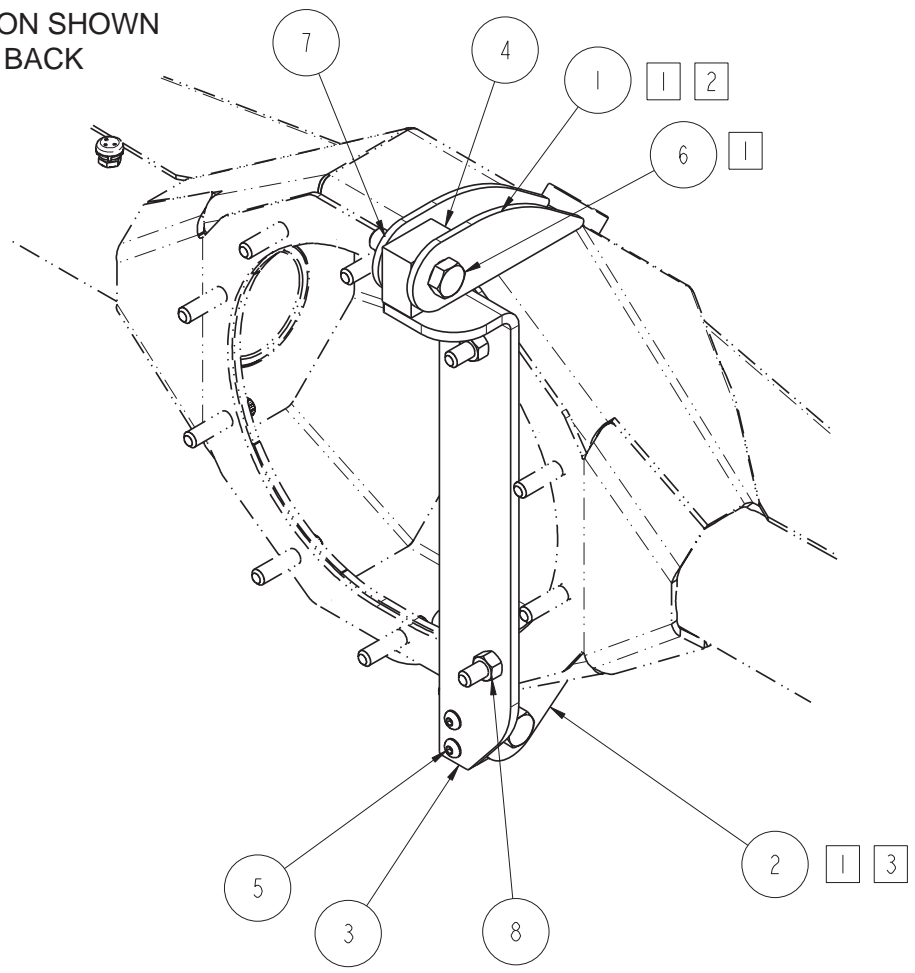

NOTES:

- 1 NOT INCLUDED WITH THIS KIT. PART OF OTHER KIT
- 2 TOP OUTER BRACKET ON STOCK FORD 9" HOUSING USE PART 7917-039
- 3 BOTTOM OUTER BRACKET ON STOCK FORD 9" HOUSING USE PART 7917-040

DESCRIPTION		WELD FIXTURE TORQUE ARM TAB, TCP	
<i>Chris Alston's</i> CHASSISWORKS INC. 8661 YOUNGER CREEK DRIVE SACRAMENTO, CA 95828 (916) 388-0288 FAX 388-0295		PART NO.	
		TCP TABKT-1	
		5/15/06	DWG: 7903-TABKT-1

FAB9/FORD 9” PARTS LIST

TCP TABKT-1 Torque Arm Bracket Installation Tool

Qty	Part Number	Description
2	7917-037	Locater block housing tabs weld fixture
1	7917-038	Locater block support torque arm weld fixture
2	3102-050-20RC	Jam nut 1/2-20 RH thread
4	3104-025C0.63C	Button head 1/4-20 x 5/8” cap screw
2	3110-038-24-5C	Hex nut 3/8-24

TCP TABKT-2 Torque Arm Bracket Set for **Ford 9” Housing**

Qty	Part Number	Description
1	7917-027	Upper-inside bracket
1	7917-028	Lower-inside bracket
1	7917-039	Upper-outside bracket
1	7917-040	Lower-outside bracket

TCP TABKT-3 Torque Arm Bracket Set for **Chassisworks FAB9 Housings**

Qty	Part Number	Description
2	7917-027	Upper-inside and -outside bracket
2	7917-028	Lower-inside and -outside bracket

FAB9/FORD 9” INSTRUCTIONS

1. Attach the top brackets as shown using the 1/2-20 x 2” hex bolt included with the torque arm hardware bag and the 1/2-20 hex jam nut included with this kit. DO NOT use the nylock nuts from the torque arm hardware bag. The heat from welding could destroy the locking feature.
NOTE: The outer bracket for the stock style Ford 9” housing will be part number 7917-039 from parts kit TCP TABKT-2.
2. Attach the bottom brackets as shown using the 1/2-20 x 2” hex bolt included with the torque arm hardware bag and the included 1/2-20 hex jam nut. DO NOT use the nylon insert lock nuts from the torque arm hardware bag. The heat from welding could destroy the locking feature.
NOTE: The outer bracket for the stock style Ford 9” housing will be part number 7917-040 from parts kit TCP TABKT-2.
3. It’s very important to minimize the gap between the housing and the bracket before welding. Any shrinkage that may occur during welding could change the relationship between the upper and lower bracket holes. This could make it very difficult to assembly the torque arm to the housing.
4. The housing surfaces may float with respect to the third member mounting studs. Adjust the brackets by sanding if necessary to fit as tightly as possible to the housing.
5. If there is an excessive gap, make the bracket longer by welding on the short surface to build it up. This will help reduce the free area which could cause excessive shrinkage during welding.
6. Tack the brackets at both ends and the middle. Also, place a tack at any gaps to help control shrinkage.
7. Weld the brackets to the housing. Weld both sides of each bracket.
8. Let the welds cool before removing the fixture. DO NOT use water to rapidly cool welds. This could cause excessive shrinkage and cracking of the welds.

FORD 8" PARTS LIST

TCP TABKT-4 Torque Arm Bracket Set for Ford 8" Housing

Qty	Part Number	Description
1	7917-046	Upper-inside bracket
1	7917-047	Upper-outside bracket
1	7917-048	Lower-inside bracket
1	7917-049	Lower-outside bracket

Ford 8" Fixture Position

Fixture must be clamped to housing to correctly align the torque arm with the subframe center support bracket. Due to differences in housing center sections, brackets may require trimming along bottom edge to correctly fit your housing.

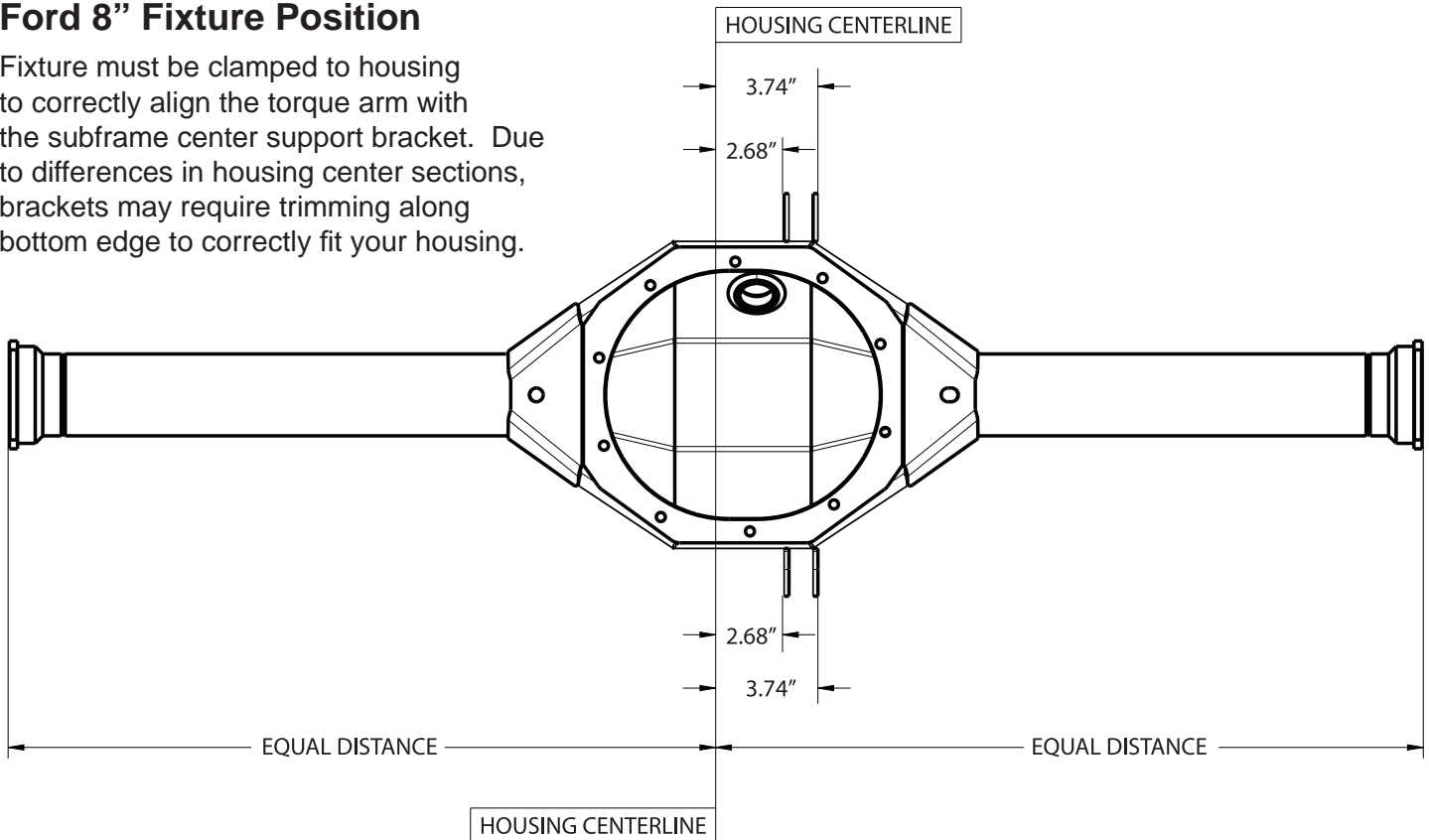

WARRANTY NOTICE:

There are NO WARRANTIES, either expressed or implied. Neither the seller nor manufacturer will be liable for any loss, damage or injury, direct or indirect, arising from the use or inability to determine the appropriate use of any products. Before any attempt at installation, all drawings and/or instruction sheets should be completely reviewed to determine the suitability of the product for its intended use. In this connection, the user assumes all responsibility and risk. We reserve the right to change specification without notice. Further, Chris Alston's Chassisworks, Inc., makes **NO GUARANTEE** in reference to any specific class legality of any component. **ALL PRODUCTS ARE INTENDED FOR RACING AND OFF-ROAD USE AND MAY NOT BE LEGALLY USED ON THE HIGHWAY.** The products offered for sale are true race-car components and, in all cases, require some fabrication skill. **NO PRODUCT OR SERVICE IS DESIGNED OR INTENDED TO PREVENT INJURY OR DEATH.**

Total Control Products
 A Chris Alston's Chassisworks, Inc. Brand
 8661 Younger Creek Drive
 Sacramento, CA 95828
 Phone: 916-388-0288
 Technical Support: tcptech@cachassisworks.com

