

## WARRANTY NOTICE:

There are **NO WARRANTIES**, either expressed or implied. Neither the seller nor manufacturer will be liable for any loss, damage or injury, direct or indirect, arising from the use or inability to determine the appropriate use of any product. Before any attempt at installation, all drawings and/or instruction sheets should be completely reviewed to determine the suitability of the product for its intended use. In this connection, the user assumes all responsibility and risk. We reserve the right to change specification without notice. Further, Chris Alston's Chassisworks, Inc., makes **NO GUARANTEE** in reference to any specific class legality of any component. **ALL PRODUCTS ARE INTENDED FOR RACING AND OFF-ROAD USE AND MAY NOT BE LEGALLY USED ON THE HIGHWAY.** The products offered for sale are true race-car components and, in all cases, require some fabrication skill. **NO PRODUCT OR SERVICE IS DESIGNED OR INTENDED TO PREVENT INJURY OR DEATH.**

## INSTALLATION GUIDE



### Poly Motor Mounts for Ford Small Blocks

**P/N: TCP MM-FD-02**



#### Total Control Products

A Chris Alston's Chassisworks, Inc. Brand

Rancho Cordova, CA 95742

Phone: 916-388-0288

Technical Support: [tcptech@cachassisworks.com](mailto:tcptech@cachassisworks.com)

7903-MM-FD-02

REV 11/07/24

#### DESCRIPTION:

MOTOR MOUNTS WITH POLY BUSHINGS FOR FORD SMALL BLOCKS (260, 289, 302 and 351W). CONTAINS 1 DRIVER AND 1 PASSENGER SIDE MOUNT WITH INSTALLED BUSHINGS AND 4 FRAME ADAPTERS.

#### APPLICATIONS:

FITS 1967-1970 COUGAR, 1964-1970 MUSTANG, 1960-65 FALCON AND RELATED MODELS

## PARTS LIST

Part #	Description	Qty
2128	Spacer .50 x 1.85 x .25 Thick	4
7901-002	Motor Mount Frame Adapter	4
7901-028	Motor Mount Driver Side	1
7901-029	Motor Mount Passenger Side	1
7901-005	Poly Bushing 1.645 OD1 x 1.265 OD	4
3140-1624-056	Sleeve 3/4 x .120 DOM x 1.750	2
<b>Hardware Bag</b>		
Part #	Description	Qty
3100-038C3.50Y	Bolt 3/8-16 x 3-1/2" Hex Head Cap Screw	6
3100-044C1.25Y	Bolt 7/16-14 x 1-1/4" Hex Head Cap Screw	4
3100-050C3.75Y	Bolt 1/2-13 x 3-3/4" Hex Head Cap Screw	2
3101-038-16C	Locknut 3/8-16 Nylon Insert	6
3101-050-13C	Locknut 1/2-13 Nylon Insert	2
3108-044L-C	Lock Washer 7/16	4
3120-050S-Y	Washer 1/2 Flat SAE .531 x 1.062 x .095	4
3157-038S-C	Washer 3/8 Flat SAE .406 x .812 x .065	12
3157-044S-C	Washer 7/16 Flat SAE .469 x .922 x .065	4

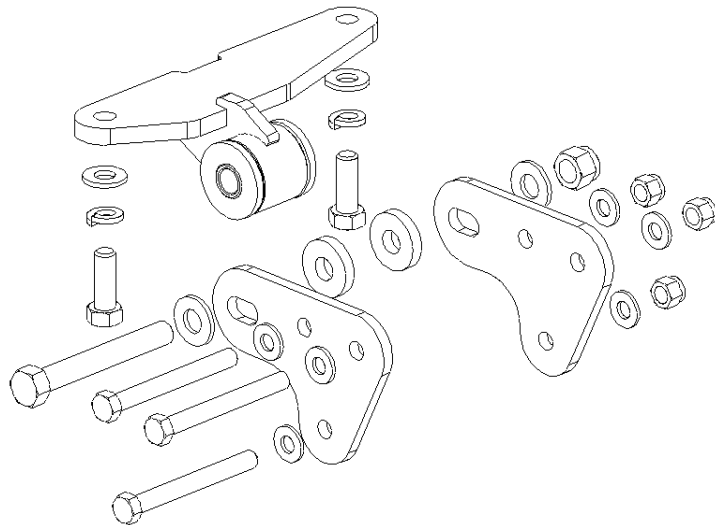

## INSTRUCTIONS

### REMOVAL

1. Disconnect the negative terminal of the battery to prevent any short circuits.
2. Support and secure the weight of the motor using a floor jack, cherry picker, or lift.
3. Remove the bolt connecting the factory motor mount to the frame mount. To ensure the engine is secure in the vehicle at all times, we recommend removing only one motor mount at this time.
4. Raise the motor to allow access to the factory mounting bolts.
5. Remove the factory motor mount and frame bracket.

### INSTALLATION

1. Loosely bolt the two frame brackets to the shock tower using the three 3/8" bolts supplied. 1967-1970 vehicles will only use two bolts for this step.
2. Using the 7/16" x 1-1/4" bolts, fasten the motor mount assembly to the engine block.
3. Lower the engine into position.
4. Insert the spacers between the bushings and the frame brackets.
5. Insert a 1/2" bolt through the assembly as shown in diagram below.
6. Torque Values: 3/8" = 30 lb/ft; 7/16" = 50 lb/ft; 1/2" = 75 lb/ft.
7. Repeat procedure for remaining mount.

