

**READ ALL INSTRUCTIONS COMPLETELY AND THOROUGHLY UNDERSTAND THEM BEFORE DOING ANYTHING.  
CALL TOTAL CONTROL PRODUCTS TECH SUPPORT (916) 388-0288 IF YOU NEED ASSISTANCE.**

# INSTALLATION GUIDE



## TCP SUBFC-03

**Weld-in Subframe Connector (Hardtop Models)  
1960-65 Falcon, Comet, Ranchero**



**Description:** Weld-in subframe connectors; connects front and rear frame rails to increase chassis rigidity  
**Applications:** Falcon '60-65, Comet '60-65, Ranchero '60-65

ITEM	QTY	PART NO.	DESCRIPTION
1	1	7962-5096	SUBFRAME CONNECTOR, DRIVER, 1960-65 FORD FALCON
2	1	7962-5097	SUBFRAME CONNECTOR, PASSENGER, 1960-65 FORD FALCON

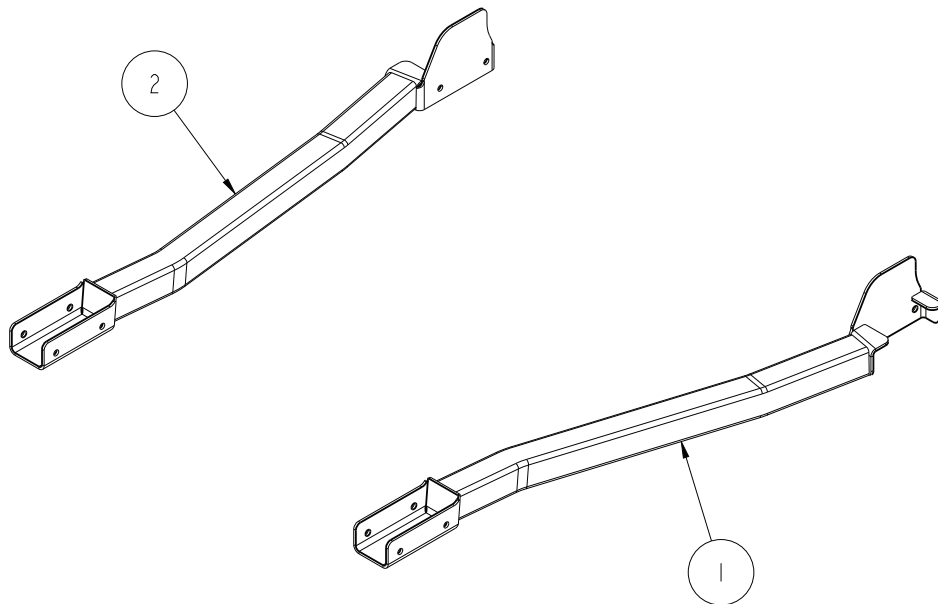

DESCRIPTION  
**SUBFRAME CONNECTORS, WELD-IN, HARDTOP,  
1960-65 FALCON, COMET, RANCHERO**

*Chris Alston's* **CHASSISWORKS INC.**  
8661 YOUNGER CREEK DRIVE  
SACRAMENTO, CA 95828  
(916) 388-0288 FAX 388-0295

PART NO.

**TCP SUBFC-03**

10/17/22

DWG: TCP\_SUBFC-03

# PARTS LIST

## TCP SUBFC-03 - Subframe Connectors '60-65 Falcon

Qty	Part Number	Description
1	7962-5096	Connector weldment driver side hardtop
1	7962-5097	Connector weldment passenger side hardtop

## INSTRUCTIONS

*NOTE: A 1965 Mustang was used for the following images and may show slight differences from the Falcon platforms. The installation procedure is identical.*

### Remove OEM Components

1. Remove carpet, insulation and wiring from areas of floorboard that will be affected by heat from welding. This is done to reduce the risk of damage and potential fire.
2. Temporarily relocate fuel and brake lines that are near the installation area. Some installations may require lines to be rerouted, modified, or the subframe connectors to be notched.
3. Be sure there is adequate clearance between the fuel line and the welding area to prevent potential fire.
4. If there is jack damage to the frame rails, the metal will need to be straightened enough for the subframe connector to seat properly.

### 5. Vehicle Modifications:

Any obstructions that prevent the subframe connector from fully seating will require modification to the connector or vehicle for installation.

The emergency brake cable bracket may have to be modified on some vehicles. Grind away the spot welds on the rear of the bracket. With a cut-off wheel, remove the section of the bracket that lies against the frame rail. Grind a notch in the bracket wide enough to slip the front cup of the subframe connector into. The front cup should seat on the frame rail without interference from the bracket.



6. Position the frame connector under the vehicle and support it using a jack. The front cup fits over the end of the front frame rail and the rear plate seats along the inside of the frame rail just forward of the leaf-spring bolt.



7. Using a marker or scribe, trace the outline of the frame connector plate along the inside of the frame rail.



8. Trace the frame connector outline along the bottom of the frame rail



- Trace the front frame connector cup outline onto the front frame rail.



- Use a disc sander or steel brush attachment and drill to remove any coating or grease that may be along the weld area of the front factory frame rails.



- The marked area must be ground to bare metal to ensure a good clean weld.



12. The rear frame rail must also be ground to bare metal along the marked line.



13. Remove the powder coating from the edges of the subframe connector where welds will be made.



14. Bare metal must be exposed approximately 3/8" from all edges of the front cup.



15. The rear connector bracket must be sanded around the large plate and along the smaller bent tabs that will sit underneath the frame rail.



16. Raise the frame connector into position under the car and support it with a jack. The subframe connector is designed to seat directly against the floor pan for maximum ground clearance. It will take some pressure to fully seat the connector.



17. The front cup of the subframe connector must be seated tightly against the bottom and back edge of the factory frame rail.

18. Clamp the rear connector bracket tight against the factory frame rail.

19. Tack weld the front and rear brackets of the first connector.

DO NOT fully weld the connector at this time.



20. Raise the second frame connector into position and support with a jackstand.
21. Check the connectors for squareness by measuring diagonally from the front cup of one connector to the rear bracket of the opposite connector. Measure in both directions. The lengths should be within 1/8". Adjust the position of the connector, if needed.



22. Once the connectors are square, tack weld the front and rear brackets of the loose connector.
23. Measure the distance between the insides of the front cups. The minimum distance required to mount the bolt-in connector support is 26-5/8". If the measurement is less than 26-5/8", use a mallet and wooden block to increase the distance.



24. Once the connectors are the correct distance apart, weld the connectors to the frame rails.



25. The rear bracket is welded along the top corner of the inside of the frame rail.



26. The bent brackets are welded along the bottom of the frame rail and a bead is ran along the backside of the connector plate.



27. After the welds are completely cool, lightly scuff the bare areas with a scotch-brite pad and paint to protect from rust.



28. The subframe connector installation is complete. The connector support center section TCP SUBCS-04 can now be installed.



**NOTES:**

**WARRANTY NOTICE:**

There are NO WARRANTIES, either expressed or implied. Neither the seller nor manufacturer will be liable for any loss, damage or injury, direct or indirect, arising from the use or inability to determine the appropriate use of any products. Before any attempt at installation, all drawings and/or instruction sheets should be completely reviewed to determine the suitability of the product for its intended use. In this connection, the user assumes all responsibility and risk. We reserve the right to change specification without notice. Further, Chris Alston's Chassisworks, Inc., makes **NO GUARANTEE** in reference to any specific class legality of any component. **ALL PRODUCTS ARE INTENDED FOR RACING AND OFF-ROAD USE AND MAY NOT BE LEGALLY USED ON THE HIGHWAY.** The products offered for sale are true race-car components and, in all cases, require some fabrication skill. **NO PRODUCT OR SERVICE IS DESIGNED OR INTENDED TO PREVENT INJURY OR DEATH.**

Total Control Products  
A Chris Alston's Chassisworks, Inc. Brand  
Rancho Cordova, CA 95624  
Phone: 916-388-0288  
Technical Support: [tcptech@cachassisworks.com](mailto:tcptech@cachassisworks.com)

